



# **PMS15B/PMS150G Family**

## **8bit OTP Type IO Controller**

### ***Data Sheet***

***Version 0.09 – Aug. 23, 2024***

Copyright © 2024 by PADAUK Technology Co., Ltd., all rights reserved

6F-6, No.1, Sec. 3, Gongdao 5th Rd., Hsinchu City 30069, Taiwan, R.O.C.

TEL: 886-3-572-8688  [www.padauk.com.tw](http://www.padauk.com.tw)

### **IMPORTANT NOTICE**

**PADAUK Technology reserves the right to make changes to its products or to terminate production of its products at any time without notice. Customers are strongly recommended to contact PADAUK Technology for the latest information and verify whether the information is correct and complete before placing orders.**

**PADAUK Technology products are not warranted to be suitable for use in life-support applications or other critical applications. PADAUK Technology assumes no liability for such applications. Critical applications include, but are not limited to, those that may involve potential risks of death, personal injury, fire or severe property damage.**

**Any programming software provided by PADAUK Technology to customers is of a service and reference nature and does not have any responsibility for software vulnerabilities. PADAUK Technology assumes no responsibility for any issue caused by a customer's product design. Customers should design and verify their products within the ranges guaranteed by PADAUK Technology. In order to minimize the risks in customers' products, customers should design a product with adequate operating safeguards.**

### Table of Contents

|  |           |
|--|-----------|
| <b>Revision History</b> .....  | <b>6</b>  |
| <b>Usage Warning</b> .....   | <b>6</b>  |
| <b>1. Features</b> .....   | <b>7</b>  |
| 1.1. Special features .....  | 7         |
| 1.2. System Features .....   | 7         |
| 1.3. CPU Features .....  | 7         |
| 1.4. Ordering/ Package Information.....  | 7         |
| 1.5. Major Differences Table between PMS15B/PMS150G and PMS15A/PMS150C.....                        | 8         |
| <b>2. General Description and Block Diagram</b> .....  | <b>8</b>  |
| <b>3. Pin Functional Description</b> .....   | <b>9</b>  |
| <b>4. Device Characteristics</b> .....   | <b>11</b> |
| 4.1. DC/AC Characteristics .....   | 11        |
| 4.2. Absolute Maximum Ratings.....   | 12        |
| 4.3. Typical IHRC Frequency vs. VDD (calibrated to 16MHz).....                                     | 13        |
| 4.4. Typical ILRC Frequency vs. VDD.....   | 13        |
| 4.5. Typical IHRC Frequency vs. Temperature (calibrated to 16MHz).....                             | 14        |
| 4.6. Typical ILRC Frequency vs. Temperature .....  | 14        |
| 4.7. Typical Operating Current vs. VDD and CLK=IHRC/n.....   | 15        |
| 4.8. Typical Operating Current vs. VDD and CLK=ILRC/n.....   | 15        |
| 4.9. Typical IO pull high resistance.....  | 16        |
| 4.10. Typical IO pull high resistance vs. Temperature, VDD=5V .....                                | 16        |
| 4.11. Typical IO pull Low resistance.....  | 17        |
| 4.12. Typical IO pull low resistance vs. Temperature, VDD=5V.....                                  | 17        |
| 4.13. Typical IO driving current (I <sub>OH</sub> ) and sink current (I <sub>OL</sub> ) .....      | 18        |
| 4.14. Typical IO input high/low threshold voltage (V <sub>IH</sub> /V <sub>IL</sub> ) .....        | 18        |
| 4.15. Typical power down current (I <sub>PD</sub> ) and power save current (I <sub>PS</sub> )..... | 19        |
| <b>5. Functional Description</b> .....   | <b>20</b> |
| 5.1. Program Memory – OTP .....  | 20        |
| 5.2. Boot Procedure .....  | 20        |
| 5.2.1. Timing charts for reset conditions .....  | 21        |
| 5.3. Data Memory – SRAM .....  | 22        |

|           |   |           |
|-----------|---|-----------|
| 5.4.      | Oscillator and clock .....  | 22        |
| 5.4.1.    | Internal High RC oscillator and Internal Low RC oscillator .....                                  | 22        |
| 5.4.2.    | IHRC calibration .....  | 22        |
| 5.4.3.    | IHRC Frequency Calibration and System Clock.....  | 23        |
| 5.4.4.    | System Clock and LVR levels.....  | 24        |
| 5.4.5.    | System Clock Switching .....  | 25        |
| 5.5.      | Comparator.....   | 26        |
| 5.5.1.    | Internal reference voltage ( $V_{\text{internal R}}$ ).....                                       | 27        |
| 5.5.2.    | Using the comparator .....  | 29        |
| 5.5.3.    | Using the comparator and bandgap 1.20V.....   | 30        |
| 5.6.      | 16-bit Timer (Timer16) .....  | 31        |
| 5.7.      | 8-bit timer (Timer2) with PWM generation .....  | 32        |
| 5.7.1.    | Using the Timer2 to generate periodical waveform .....  | 33        |
| 5.7.2.    | Using the Timer2 to generate 8-bit PWM waveform.....  | 34        |
| 5.7.3.    | Using the Timer2 to generate 6-bit PWM waveform.....  | 36        |
| 5.8.      | Watchdog Timer.....   | 37        |
| 5.9.      | Interrupt .....   | 38        |
| 5.10.     | Power-Save and Power-Down .....   | 40        |
| 5.10.1.   | Power-Save mode (“stopexe”).....  | 41        |
| 5.10.2.   | Power-Down mode (“stopsys”) .....   | 42        |
| 5.10.3.   | Wake-up.....  | 42        |
| 5.11.     | IO Pins.....  | 43        |
| 5.12.     | Reset .....   | 44        |
| 5.12.1.   | Reset.....  | 44        |
| 5.12.2.   | LVR reset .....   | 44        |
| <b>6.</b> | <b>IO Registers.....</b>  | <b>45</b> |
| 6.1.      | ACC Status Flag Register ( <i>flag</i> ), IO address = 0x00 .....                                 | 45        |
| 6.2.      | Stack Pointer Register ( <i>sp</i> ), IO address = 0x02.....                                      | 45        |
| 6.3.      | Clock Mode Register ( <i>clkmd</i> ), IO address = 0x03 .....                                     | 45        |
| 6.4.      | Interrupt Enable Register ( <i>inten</i> ), IO address = 0x04.....                                | 45        |
| 6.5.      | Interrupt Request Register ( <i>intrq</i> ), IO address = 0x05 .....                              | 46        |
| 6.6.      | Timer 16 mode Register ( <i>t16m</i> ), IO address = 0x06.....                                    | 46        |
| 6.7.      | External Oscillator setting Register ( <i>eoscr</i> , <i>write only</i> ), IO address = 0x0a..... | 46        |
| 6.8.      | Interrupt Edge Select Register ( <i>integs</i> ), IO address = 0x0c.....                          | 47        |
| 6.9.      | Port A Digital Input Enable Register ( <i>padier</i> ), IO address = 0x0d.....                    | 47        |
| 6.10.     | Port A Data Registers ( <i>pa</i> ), IO address = 0x10 .....                                      | 47        |
| 6.11.     | Port A Control Registers ( <i>pac</i> ), IO address = 0x11.....                                   | 47        |

|           |  |           |
|-----------|--|-----------|
| 6.12.     | Port A Pull-High Registers ( <i>paph</i> ), IO address = 0x12.....     | 47        |
| 6.13.     | Port A Pull-Low Registers ( <i>papl</i> ), IO address = 0x13.....      | 47        |
| 6.14.     | MISC Register ( <i>misc</i> ), IO address = 0x1b .....                 | 48        |
| 6.15.     | Comparator Control Register ( <i>gpcc</i> ), IO address = 0x1A.....    | 48        |
| 6.16.     | Comparator Selection Register ( <i>gpcs</i> ), IO address = 0x1E ..... | 49        |
| 6.17.     | Timer2 Control Register ( <i>tm2c</i> ), IO address = 0x1C.....        | 49        |
| 6.18.     | Timer2 Counter Register ( <i>tm2ct</i> ), IO address = 0x1D.....       | 50        |
| 6.19.     | Timer2 Bound Register ( <i>tm2b</i> ), IO address = 0x09 .....         | 50        |
| 6.20.     | Timer2 Scalar Register ( <i>tm2s</i> ), IO address = 0x17 .....        | 50        |
| <b>7.</b> | <b>Instructions .....</b>  | <b>51</b> |
| 7.1.      | Data Transfer Instructions .....                                       | 52        |
| 7.2.      | Arithmetic Operation Instructions .....                                | 55        |
| 7.3.      | Shift Operation Instructions .....                                     | 56        |
| 7.4.      | Logic Operation Instructions.....                                      | 57        |
| 7.5.      | Bit Operation Instructions .....                                       | 59        |
| 7.6.      | Conditional Operation Instructions .....                               | 59        |
| 7.7.      | System control Instructions .....                                      | 60        |
| 7.8.      | Summary of Instructions Execution Cycle .....                          | 62        |
| 7.9.      | Summary of affected flags by Instructions .....                        | 63        |
| 7.10.     | BIT definition .....   | 63        |
| <b>8.</b> | <b>Code Options .....</b>  | <b>64</b> |
| <b>9.</b> | <b>Special Notes .....</b>   | <b>65</b> |
| 9.1.      | Using IC.....  | 65        |
| 9.1.1.    | IO pin usage and setting.....  | 65        |
| 9.1.2.    | Interrupt.....   | 65        |
| 9.1.3.    | System clock switching.....  | 66        |
| 9.1.4.    | Power down mode, wakeup and watchdog.....                              | 66        |
| 9.1.5.    | TIMER time out.....  | 66        |
| 9.1.6.    | IHRC .....   | 66        |
| 9.1.7.    | LVR .....  | 67        |
| 9.1.8.    | Program writing .....  | 67        |
| 9.2.      | Using ICE.....   | 69        |

### Revision History

| Revision | Date       | Description   |
|----------|------------|---|
| 0.09     | 2024/08/23 | 1. Updated description of Special Features<br>2. Modify the value of Scalar |

### Usage Warning

User must read all application notes of the IC by detail before using it.

Please visit the official website to download and view the latest APN information associated with it.

<http://www.padauk.com.tw/en/product/show.aspx?num=123&kw=PMS150G>

(The following picture are for reference only.)

Feature
Documents
Software & Tools
Application Note

| Content | Description  | Download (CN)     | Download (EN)     |
|---------|--|-------------------|-------------------|
| APN002  | Over voltage protection                                  | <a href="#">↓</a> | <a href="#">↓</a> |
| APN003  | Over voltage protection                                  | <a href="#">↓</a> | <a href="#">↓</a> |
| APN004  | Semi-Automatic writing handler                           | <a href="#">↓</a> | <a href="#">↓</a> |
| APN007  | Setting up LVR level                                     | <a href="#">↓</a> | <a href="#">↓</a> |
| APN011  | Semi-Automatic writing Handler improve writing stability | <a href="#">↓</a> | <a href="#">↓</a> |
| APN016  | PMS150G Writing Guide                                    | <a href="#">↓</a> | <a href="#">↓</a> |

## 1. Features

### 1.1. Special features

- ◆ General purpose series
- ◆ In applications with AC RC step-down power supply or high EFT requirements, the system circuit needs to be modified if necessary to improve the anti-interference capability
- ◆ Operating temperature range: -40°C ~ 85°C

### 1.2. System Features

| Series  | Program memory | Data memory (byte) | Maximum IO quantity |
|---------|----------------|--------------------|---------------------|
| PMS150G | 1KW            | 64                 | 6                   |
| PMS15B  | 0.5KW          | 64                 | 6                   |

- ◆ One hardware 16-bit timer
- ◆ One hardware 8-bit timer with PWM generation
- ◆ One general purpose comparator
- ◆ Support fast/normal wake-up
- ◆ Every IO pin can be configured to enable wake-up function
- ◆ 6 IO pins with pull-high/pull-low resistor
- ◆ Clock sources: internal high RC oscillator and internal low RC oscillator
- ◆ Eight levels of LVR: 4.0V, 3.5V, 3.0V, 2.75V, 2.5V, 2.2V, 2.0V, 1.8V
- ◆ One external interrupt pin

### 1.3. CPU Features

- ◆ One processing unit operating mode
- ◆ 79 Powerful instructions
- ◆ Most instructions are 1T execution cycle
- ◆ Programmable stack pointer and adjustable stack level
- ◆ Direct and indirect addressing modes for data access. Data memories are available for use as an index pointer of Indirect addressing mode
- ◆ IO space and memory space are independent

### 1.4. Ordering/ Package Information

#### ◆ PMS150G Series

- ◇ PMS150G- U06: SOT23-6 (60mil);
- ◇ PMS150G- S08: SOP8 (150mil);
- ◇ PMS150G- D08: DIP8 (300mil)

#### ◆ PMS15B Series

- ◇ PMS15B- U06: SOT23-6 (60mil);
- ◇ PMS15B- S08: SOP8 (150mil);
- ◇ PMS15B- D08: DIP8 (300mil)

- Please refer to the official website file for package size information: "Package information "

### 1.5. Major Differences Table between PMS15B/PMS150G and PMS15A/PMS150C

| Item | Function                | PMS15B/PMS150G         | PMS15A/PMS150C    |
|------|-------------------------|------------------------|-------------------|
| 1    | Operating Voltage Range | 1.8 ~ 5.5V             | 2.0 ~ 5.5V        |
| 2    | Input Option            | Pull-High / Pull-Low   | Pull-High ONLY    |
| 3    | PA5 Mode                | Normal IO / Open-Drain | Open-Drain        |
| 4    | Programming Writer      | 5S-P003                | 3S-P002 / 5S-P003 |
| 5    | IO Drive Option         | Normal                 | Normal / Low      |

## 2. General Description and Block Diagram

The PMS15B/PMS150G is an IO-Type, fully static, OTP-based CMOS 8-bit microcontroller; it employs RISC architecture and most the instructions are executed in one cycle except that few instructions are two cycles that handle indirect memory access.

1KW bits OTP program memory and 64 bytes data SRAM are inside. Besides, one hardware 16-bit timer, one hardware 8-bit timer with PWM generation and one general purpose comparator are also provided in the PMS15B/PMS150G.

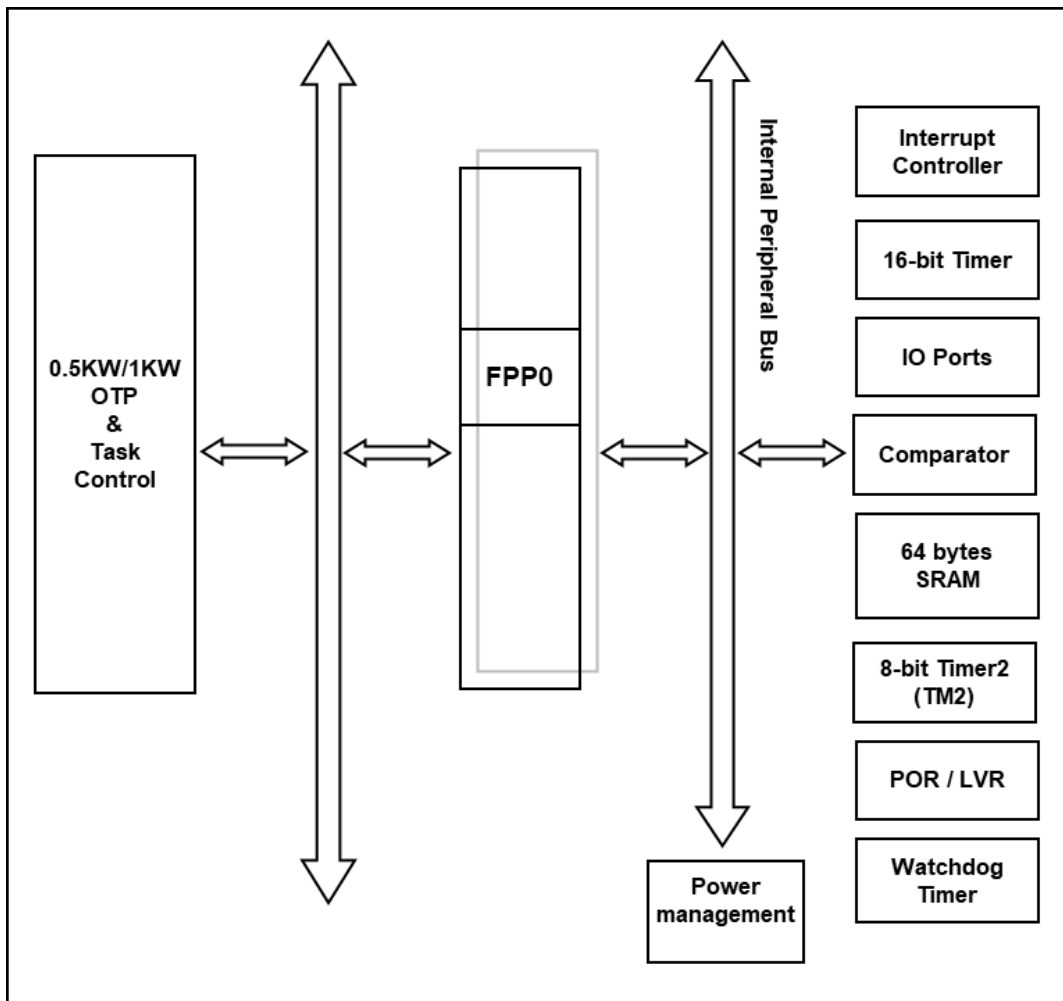



### 3. Pin Functional Description

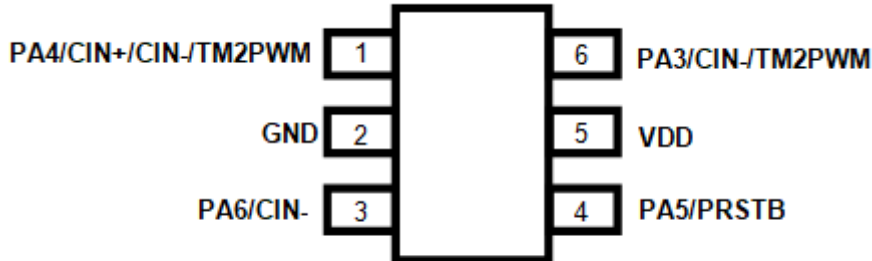

**PMS15B/PMS150G -U06 (SOT23-6 60mil)**

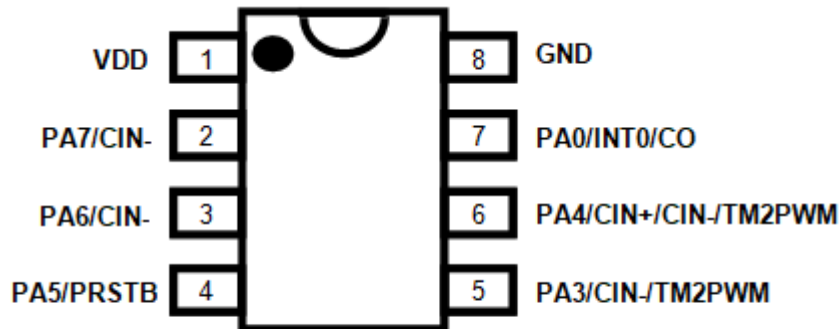

**PMS15B/PMS150G -S08 (SOP8-150mil)**

**PMS15B/PMS150G -D08 (DIP8-300mil)**

| Pin Name      | Pin & Buffer Type              | Description  |
|---------------|--------------------------------|--|
| PA7 /<br>CIN- | IO<br>ST /<br>CMOS /<br>Analog | <p>This pin can be used as:</p> <p>(1) Bit 7 of port A. It can be configured as digital input or two-state output, with pull-high or pull-low resistor.</p> <p>(2) Minus input source of comparator.</p> <p>When this pin is configured as analog input, please use bit 7 of register <b>padier</b> to disable the digital input to prevent current leakage. This pin can be used to wake-up system during sleep mode; however, wake-up function is also disabled if bit 7 of <b>padier</b> register is "0".</p> |
| PA6 /<br>CIN- | IO<br>ST /<br>CMOS /<br>Analog | <p>This pin can be used as:</p> <p>(1) Bit 6 of port A. It can be configured as digital input or two-state output, with pull-high or pull-low resistor.</p> <p>(2) Minus input source of comparator.</p> <p>When this pin is configured as analog input, please use bit 6 of register <b>padier</b> to disable the digital input to prevent current leakage. This pin can be used to wake-up system during sleep mode; however, wake-up function is also disabled if bit 6 of <b>padier</b> register is "0".</p> |

| Pin Name  | Pin & Buffer Type              | Description  |
|---|--------------------------------|--|
| PA5 /<br>PRSTB  | IO<br>ST /<br>CMOS             | <p>The functions of this pin can be:</p> <p>(1) Bit 5 of port A. It can be configured as digital input or two-state output or Open-Drain, with pull-high or pull-low resistor.</p> <p>(2) Hardware reset.</p> <p>This pin can be used to wake-up system during sleep mode; however, wake-up function is also disabled if bit 5 of <b>padier</b> register is "0".</p> <p>Please put 33Ω resistor in series to have high noise immunity when this pin is in input mode.</p>  |
| PA4 /<br>CIN+ /<br>CIN- /<br>TM2PWM   | IO<br>ST /<br>CMOS /<br>Analog | <p>This pin can be used as:</p> <p>(1) Bit 4 of port A. It can be configured as digital input or two-state output, with pull-high or pull-low resistor.</p> <p>(2) Plus input source of comparator.</p> <p>(3) Minus input source of comparator.</p> <p>(4) Output of 8-bit Timer2 (TM2)</p> <p>When this pin is configured as analog input, please use bit 4 of register <b>padier</b> to disable the digital input to prevent current leakage. This pin can be used to wake-up system during sleep mode; however, wake-up function is also disabled if bit 4 of <b>padier</b> register is "0".</p> |
| PA3 /<br>CIN- /<br>TM2PWM   | IO<br>ST /<br>CMOS /<br>Analog | <p>This pin can be used as:</p> <p>(1) Bit 3 of port A. It can be configured as digital input or two-state output, with pull-high or pull-low resistor.</p> <p>(2) Minus input source of comparator.</p> <p>(3) Output of 8-bit Timer2 (TM2)</p> <p>When this pin is configured as analog input, please use bit 3 of register <b>padier</b> to disable the digital input to prevent current leakage. This pin can be used to wake-up system during sleep mode; however, wake-up function is also disabled if bit 3 of <b>padier</b> register is "0".</p>   |
| PA0 /<br>INT0 /<br>CO   | IO<br>ST /<br>CMOS             | <p>The functions of this pin can be:</p> <p>(1) Bit 0 of port A. It can be configured as digital input or output with pull-up or pull-low resistor.</p> <p>(2) External interrupt line 0. <u>Both rising edge and falling edge are accepted to request interrupt service.</u></p> <p>(3) Output of comparator</p> <p>This pin can be used to wake up system during sleep mode; however, wake-up function from this pin is also disabled when bit 0 of <b>padier</b> register is "0".</p>   |
| VDD   |                                | Positive power   |
| GND   |                                | Ground   |
| <b>Notes:</b> <b>IO:</b> Input/Output; <b>ST:</b> Schmitt Trigger input; <b>Analog:</b> Analog input pin; <b>CMOS:</b> CMOS voltage level |                                |  |

### 4. Device Characteristics

#### 4.1. DC/AC Characteristics

All data are acquired under the conditions of  $V_{DD}=5.0V$ ,  $f_{SYS}=2MHz$  unless noted.

| Symbol         | Description                                       | Min              | Typ  | Max             | Unit              | Conditions  |
|----------------|---|------------------|------|-----------------|-------------------|---|
| $V_{DD}$       | Operating Voltage                                 | 1.8 <sup>#</sup> |      | 5.5             | V                 | #Subject to LVR tolerance   |
| LVR%           | Low Voltage Reset tolerance                       | -5               |      | 5               | %                 |   |
| $f_{SYS}$      | System clock (CLK)* =                             |                  |      |                 |                   |   |
|                | IHRC/2  | 0                |      | 8M              | Hz                | $V_{DD} \geq 3.0V$  |
|                | IHRC/4  | 0                |      | 4M              |                   | $V_{DD} \geq 2.2V$  |
|                | IHRC/8  | 0                |      | 2M              |                   | $V_{DD} \geq 1.8V$  |
| ILRC           |   | 57KHz            |      | $V_{DD} = 5.0V$ |                   |   |
| $V_{POR}$      | Power On Reset Voltage                            | 1.7              | 1.8  | 1.9             | V                 |   |
| $I_{OP}$       | Operating Current                                 |                  | 0.3  |                 | mA                | $f_{SYS}=IHRC/16=1MIPS@3.3V$                                      |
|                |   |                  | 22   |                 | uA                | $f_{SYS}=ILRC=59KHz@3.3V$   |
| $I_{PD}$       | Power Down Current<br>(by <b>stopsys</b> command) |                  | 1    |                 | uA                | $f_{SYS}=0Hz$ , $V_{DD}=3.3V$                                     |
| $I_{PS}$       | Power Save Current<br>(by <b>stopexe</b> command) |                  | 3    |                 | uA                | $V_{DD}=3.3V$ ;<br>Bandgap, LVR, IHRC are OFF, ILRC module is ON. |
| $V_{IL}$       | Input low voltage for IO lines                    | 0                |      | $0.1 V_{DD}$    | V                 |   |
| $V_{IH}$       | Input high voltage for IO lines                   | $0.7 V_{DD}$     |      | $V_{DD}$        | V                 |   |
| $I_{OL}$       | IO lines sink current                             | 19               | 21   | 24              | mA                | $V_{DD}=5.0V$ , $V_{OL}=0.5V$                                     |
| $I_{OH}$       | PA5 (Open Drain)                                  |                  | 0    |                 | mA                | $V_{DD}=5.0V$ , $V_{OH}=4.5V$                                     |
|                | PA5 (Normal IO)                                   | -11              | -13  | -16             |                   |   |
|                | IO lines drive current                            | -11              | -13  | -16             |                   |   |
| $V_{IN}$       | Input voltage                                     | -0.3             |      | $V_{DD}+0.3$    | V                 |   |
| $I_{INJ(PIN)}$ | Injected current on pin                           |                  |      | 1               | mA                | $V_{DD} + 0.3 \geq V_{IN} \geq -0.3$                              |
| $R_{PH}$       | Pull-high Resistance                              | 76               | 84   | 96              | K $\Omega$        |   |
| $R_{PL}$       | Pull-low Resistance                               | 66               | 77   | 86              | K $\Omega$        |   |
| $f_{IHRC}$     | Frequency of IHRC after calibration*              | 15.66*           | 16*  | 16.34*          | MHz               | @25°C, $V_{DD}=2.0V\sim 5.5V$ ,                                   |
|                |   | 15.10*           | 16*  | 16.90*          |                   | $V_{DD}=2.0V\sim 5.5V$ ,<br>-40°C<Ta<85°C*                        |
| $f_{ILRC}$     | Frequency of ILRC*                                |                  | 57*  |                 | KHz               | $V_{DD}=5.0V$ , -40°C <Ta<85°C*                                   |
| $t_{INT}$      | Interrupt pulse width                             | 30               |      |                 | ns                | $V_{DD}=5.0V$   |
| $V_{DR}$       | RAM data retention voltage*                       | 1.5              |      |                 | V                 | In power-down mode.   |
| $t_{WDT}$      | Watchdog timeout period                           |                  | 8k   |                 | ILRC clock period | misc[1:0]=00 (default)  |
|                |   |                  | 16k  |                 |                   | misc[1:0]=01  |
|                |   |                  | 64k  |                 |                   | misc[1:0]=10  |
|                |   |                  | 256k |                 |                   | misc[1:0]=11  |

| Symbol            | Description  | Min | Typ        | Max                  | Unit              | Conditions  |
|-------------------|--|-----|------------|----------------------|-------------------|---|
| t <sub>SBP</sub>  | System boot-up period from power-on (Fast boot up) |     | 850<br>850 |                      | us                | @ V <sub>DD</sub> =5V<br>@ V <sub>DD</sub> =2.5V    |
|                   | System boot-up period from power-on (Slow boot up) |     | 51<br>51   |                      | ms                | @ V <sub>DD</sub> =5V<br>@ V <sub>DD</sub> =2.5V    |
| t <sub>WUP</sub>  | Wake-up time for fast wake-up (misc.5=1)           |     | 32         |                      | T <sub>ILRC</sub> | Where T <sub>ILRC</sub> is the clock period of ILRC |
|                   | Wake-up time for normal wake-up (misc.5=0)         |     | 2048       |                      | T <sub>ILRC</sub> | Where T <sub>ILRC</sub> is the clock period of ILRC |
| t <sub>RST</sub>  | External reset pulse width                         | 120 |            |                      | us                | @ V <sub>DD</sub> =5V                               |
| CP <sub>os</sub>  | Comparator offset*                                 |     | ±10        | ±20                  | mV                |   |
| CP <sub>cm</sub>  | Comparator input common mode*                      | 0   |            | V <sub>DD</sub> -1.5 | V                 |   |
| CP <sub>spt</sub> | Comparator response time*                          |     | 100        | 500                  | ns                | Both Rising and Falling                             |
| CP <sub>mc</sub>  | Stable time to change comparator mode              |     | 2.5        | 7.5                  | us                |   |
| CP <sub>cs</sub>  | Comparator current consumption                     |     | 20         |                      | uA                | V <sub>DD</sub> = 3.3V                              |

\*These parameters are for design reference, not tested for every chip.

#### 4.2. Absolute Maximum Ratings

- Supply Voltage ..... 1.8V ~ 5.5V (Maximum Rating: 5.5V)  
\*If V<sub>DD</sub> over maximum rating, it may lead to a permanent damage of IC.
- Input Voltage ..... -0.3V ~ V<sub>DD</sub> + 0.3V
- Operating Temperature ..... -40°C ~ 85°C
- Storage Temperature ..... -50°C ~ 125°C
- Junction Temperature ..... 150°C

### 4.3. Typical IHRC Frequency vs. VDD (calibrated to 16MHz)

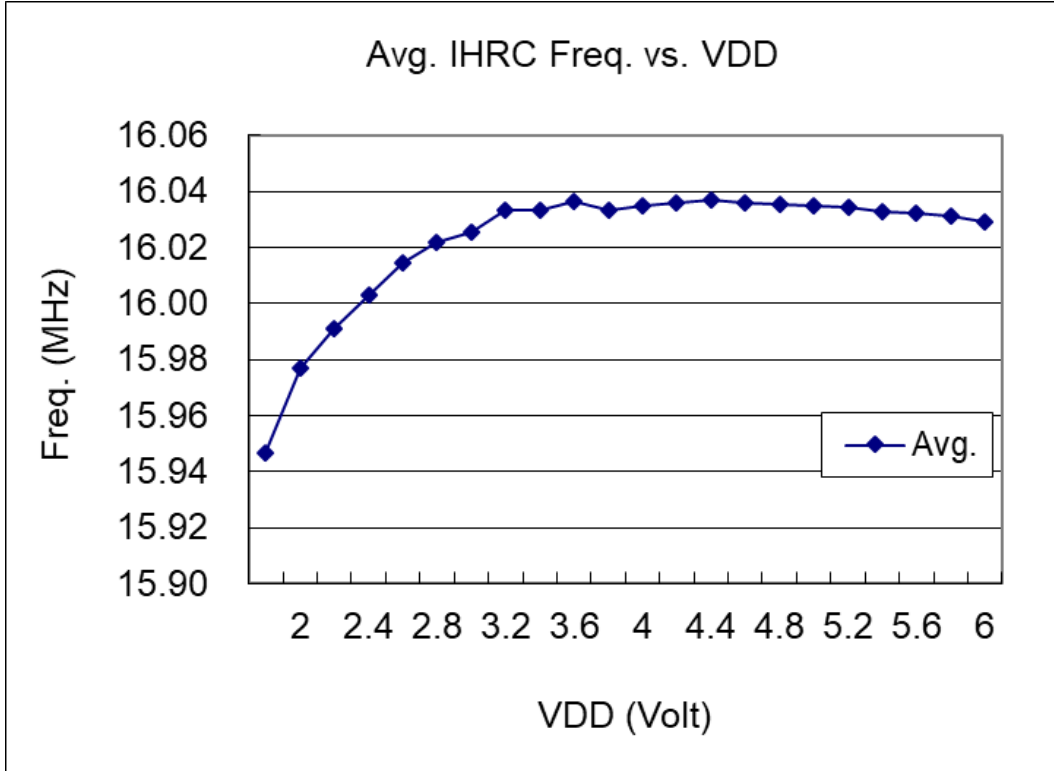

### 4.4. Typical ILRC Frequency vs. VDD

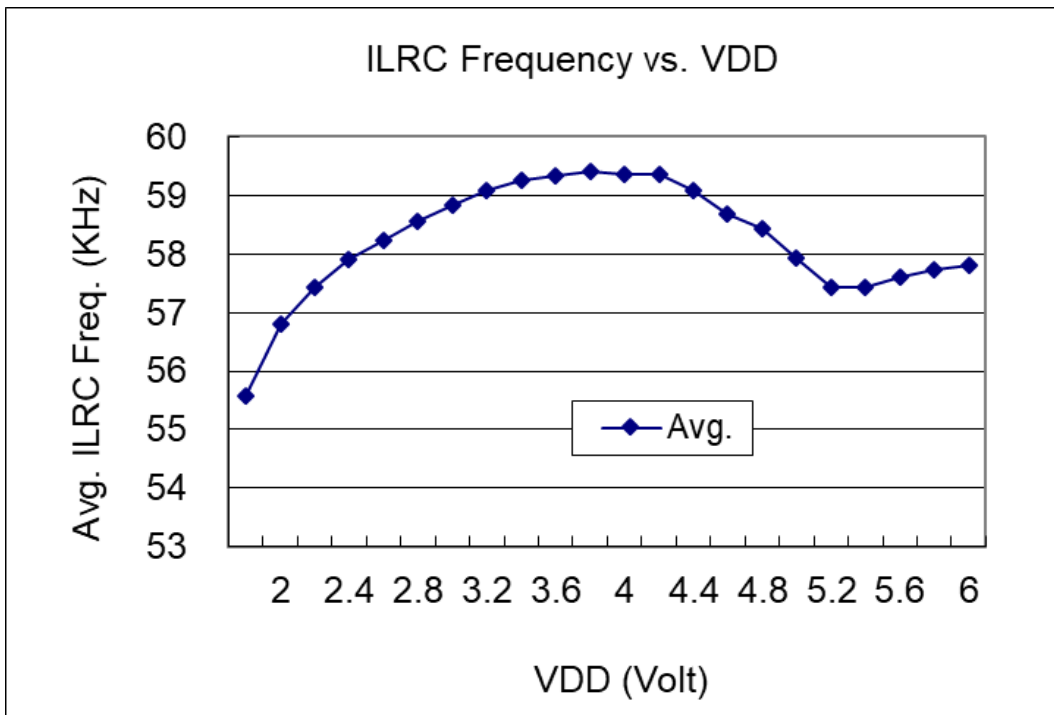

### 4.5. Typical IHRC Frequency vs. Temperature (calibrated to 16MHz)

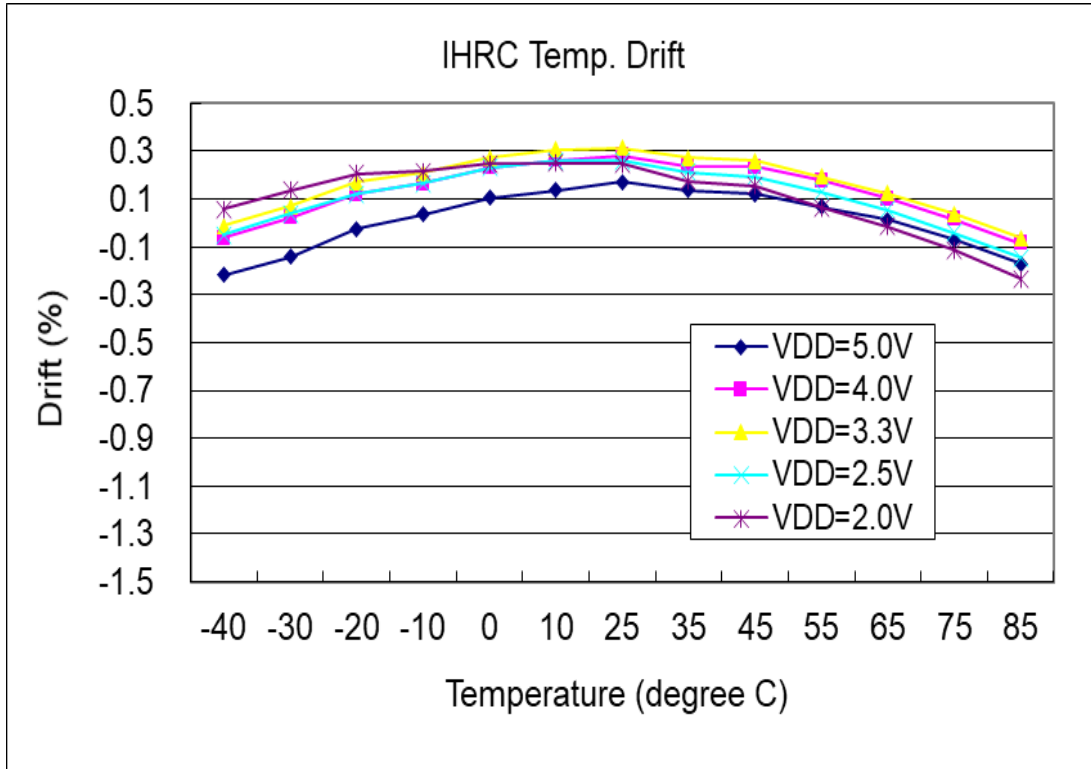

### 4.6. Typical ILRC Frequency vs. Temperature

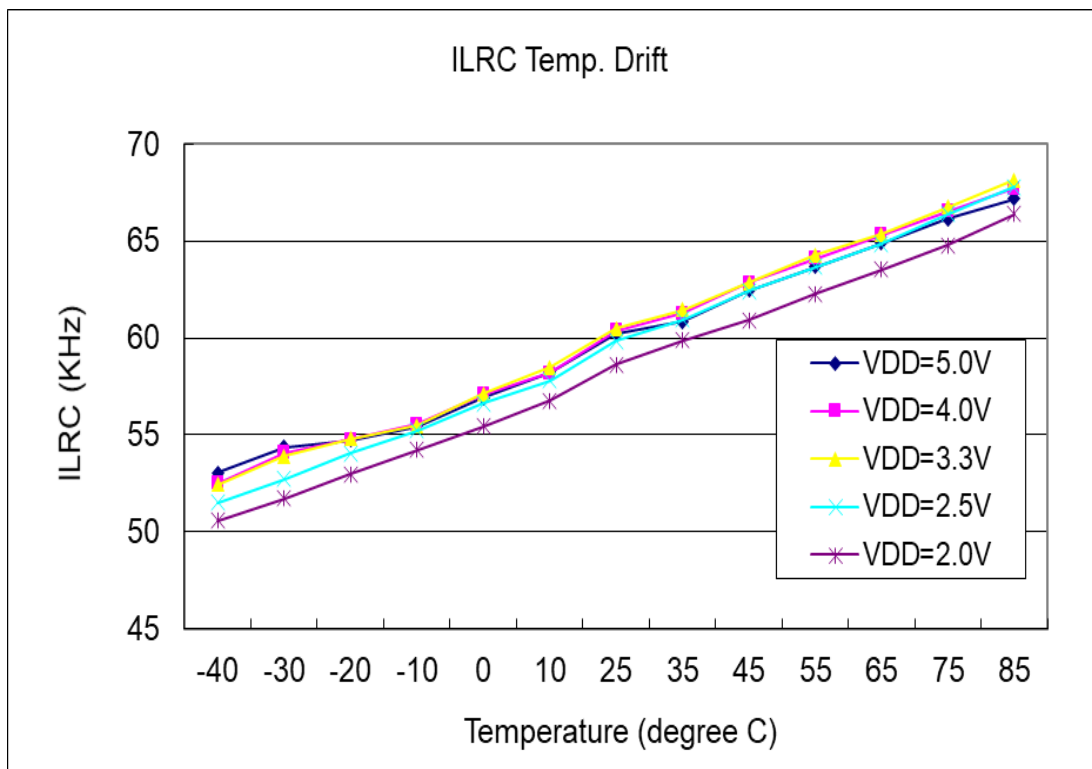

### 4.7. Typical Operating Current vs. VDD and CLK=IHRC/n

Conditions: **ON**: Bandgap, LVR, IHRC, T16 modules; **OFF**: ILRC modules;

**IO**: PA0:0.5Hz output toggle and no loading, others: input and no floating

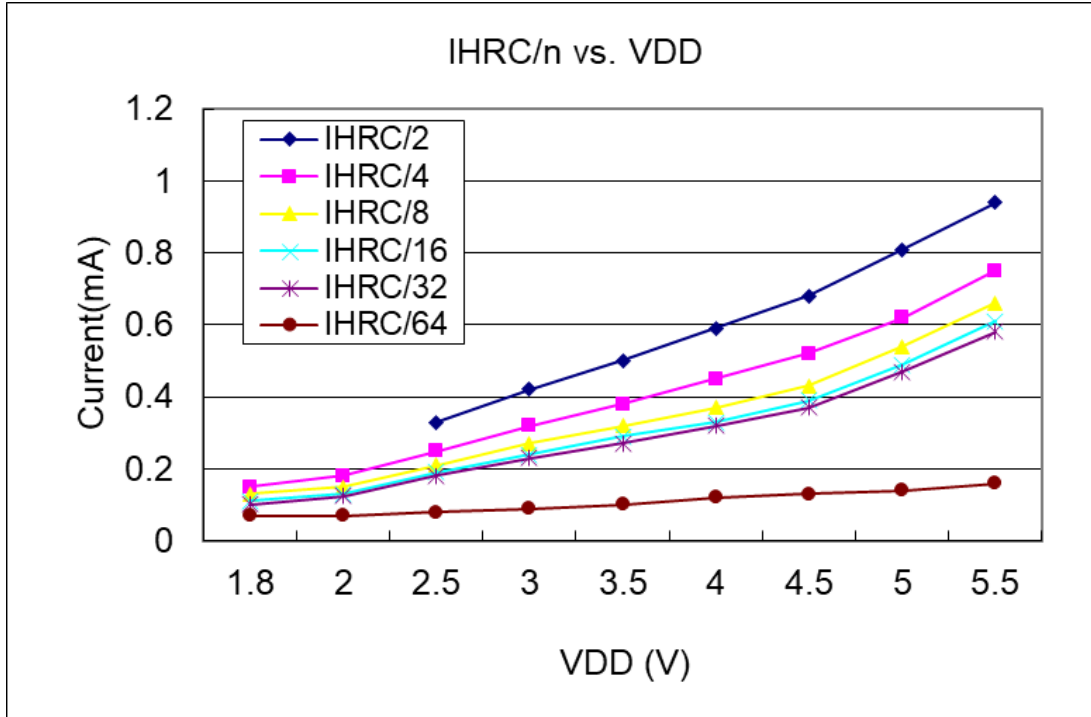

### 4.8. Typical Operating Current vs. VDD and CLK=ILRC/n

Conditions: **ON**: T16 modules; **OFF**: Bandgap, LVR, IHRC modules;

**IO**: PA0:0.5Hz output toggle and no loading, others: input and no floating

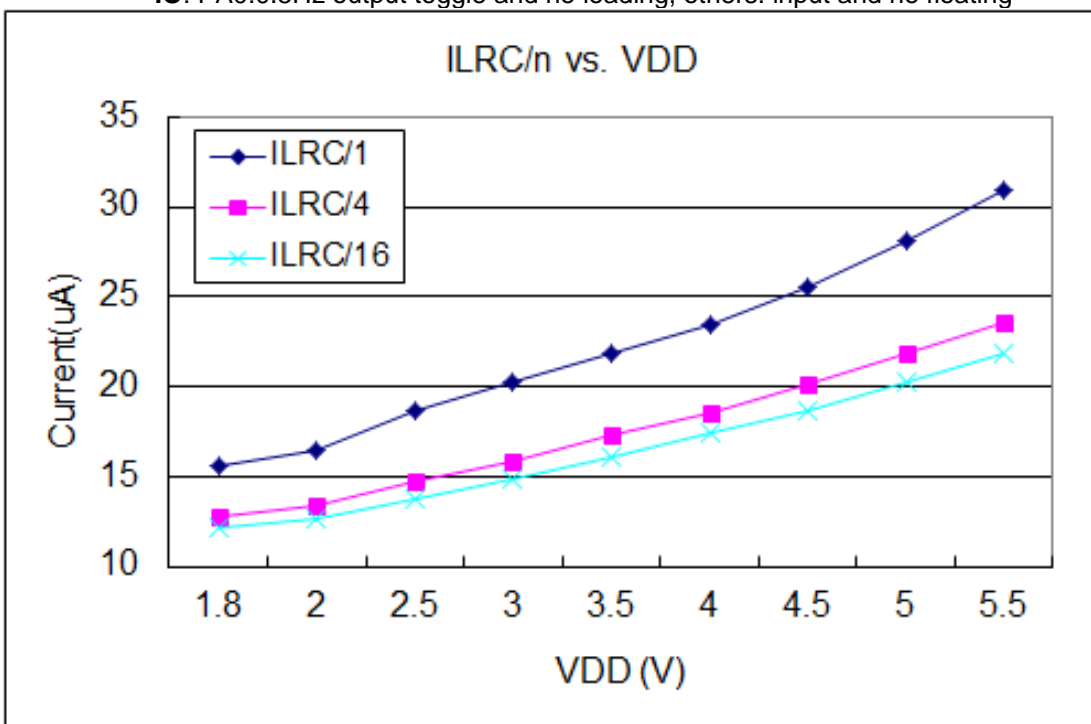

### 4.9. Typical IO pull high resistance

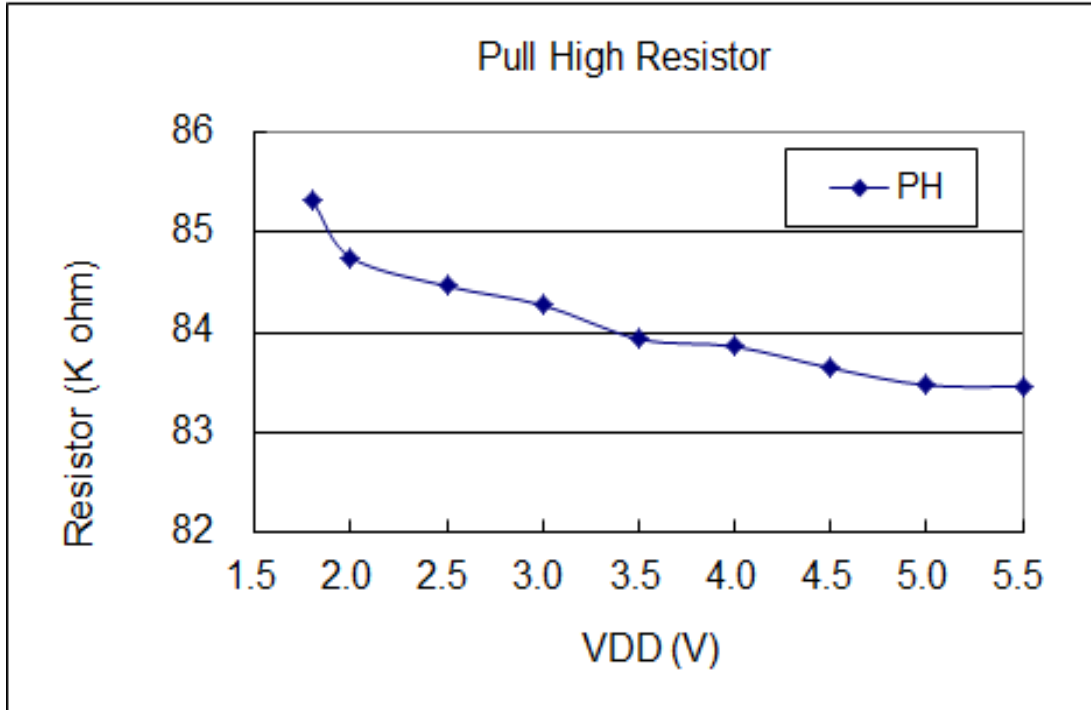

### 4.10. Typical IO pull high resistance vs. Temperature, VDD=5V

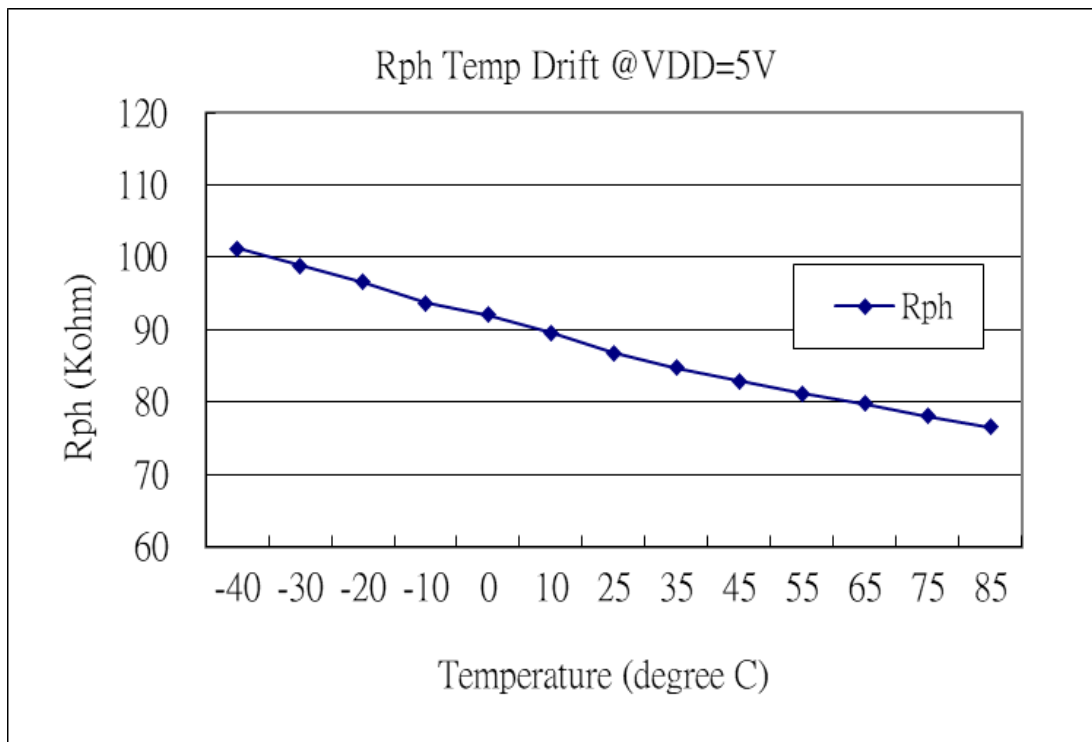



### 4.11. Typical IO pull Low resistance

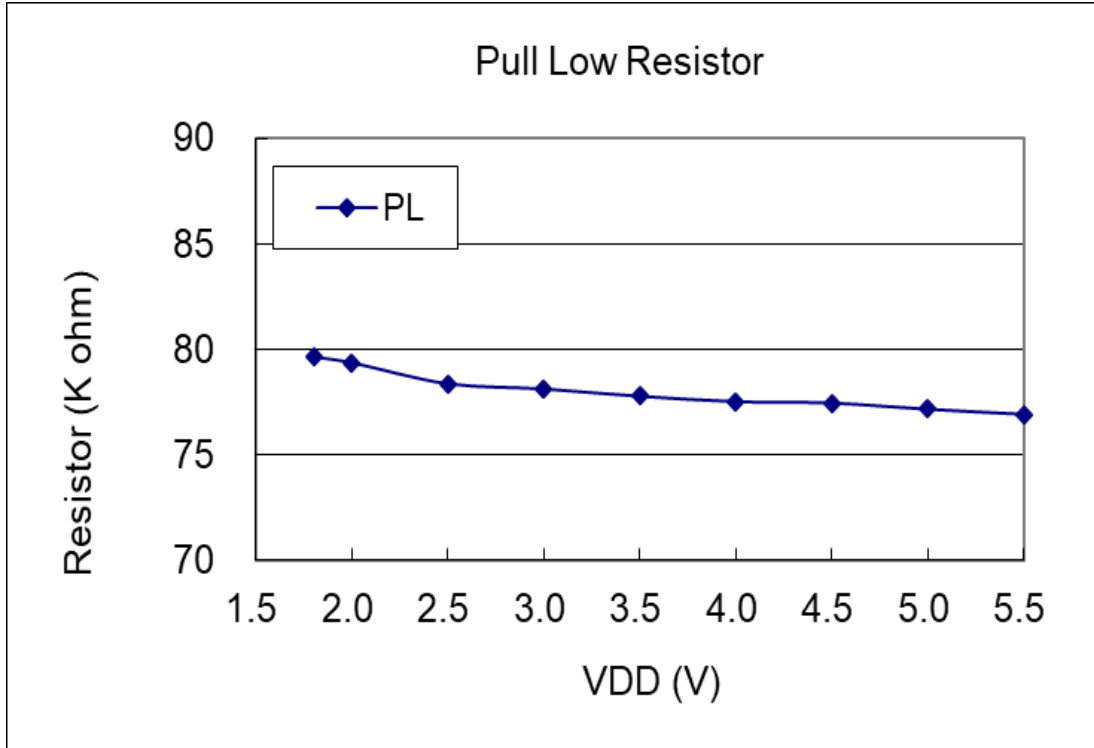

### 4.12. Typical IO pull low resistance vs. Temperature, VDD=5V

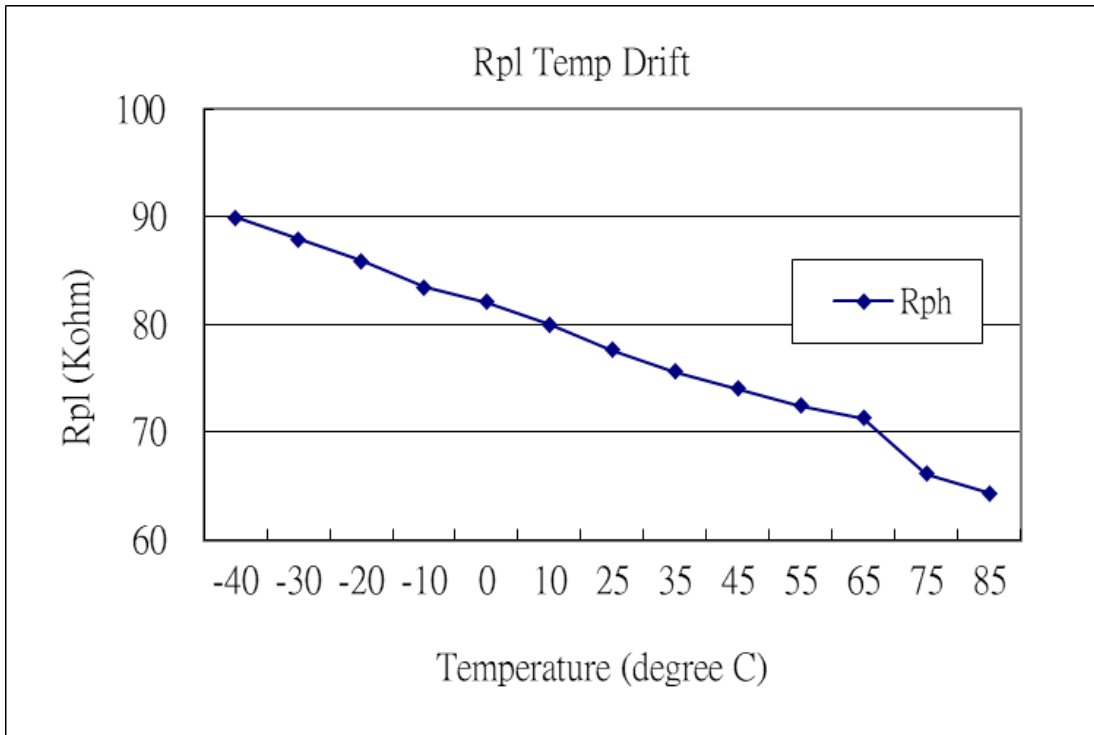

### 4.13. Typical IO driving current ( $I_{OH}$ ) and sink current ( $I_{OL}$ )

(  $V_{OH}=0.9 \cdot V_{DD}$ ,  $V_{OL}=0.1 \cdot V_{DD}$  )

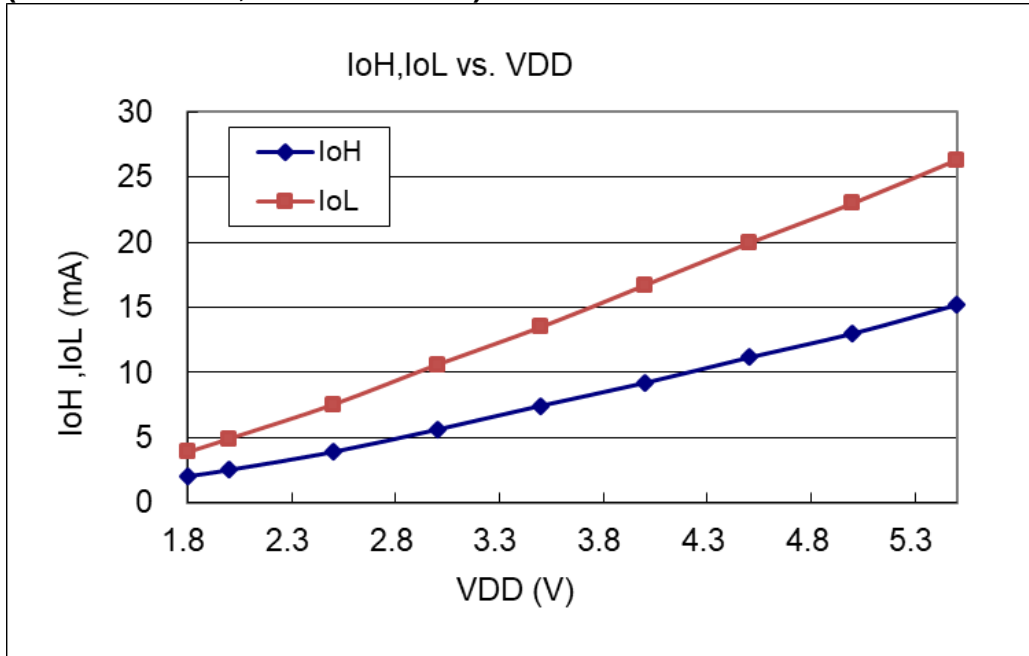

### 4.14. Typical IO input high/low threshold voltage ( $V_{IH}/V_{IL}$ )

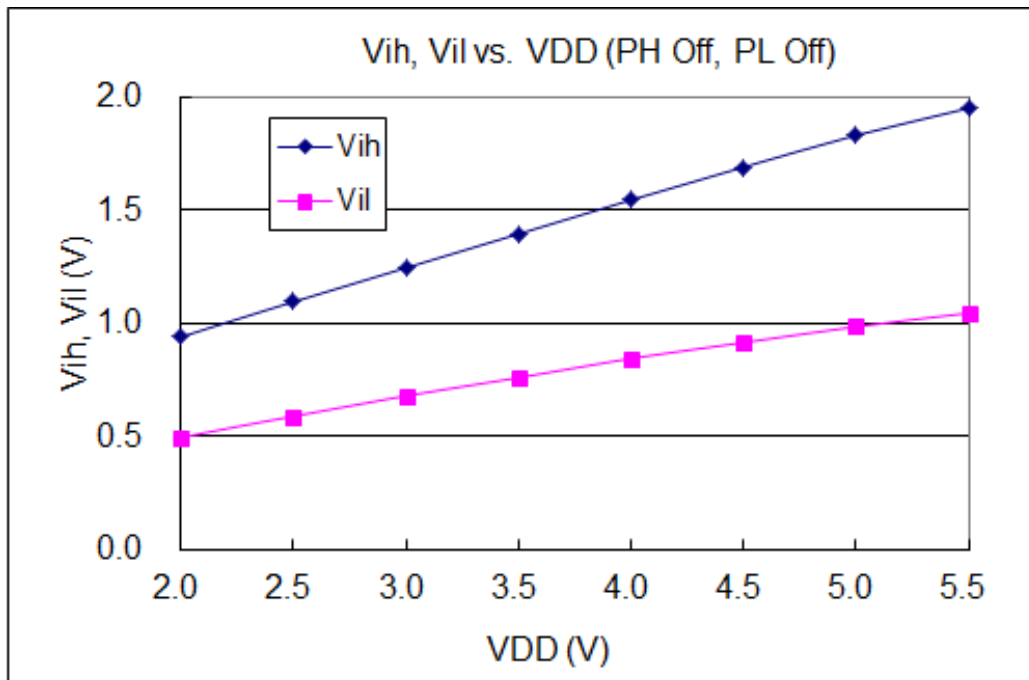

### 4.15. Typical power down current ( $I_{PD}$ ) and power save current ( $I_{PS}$ )

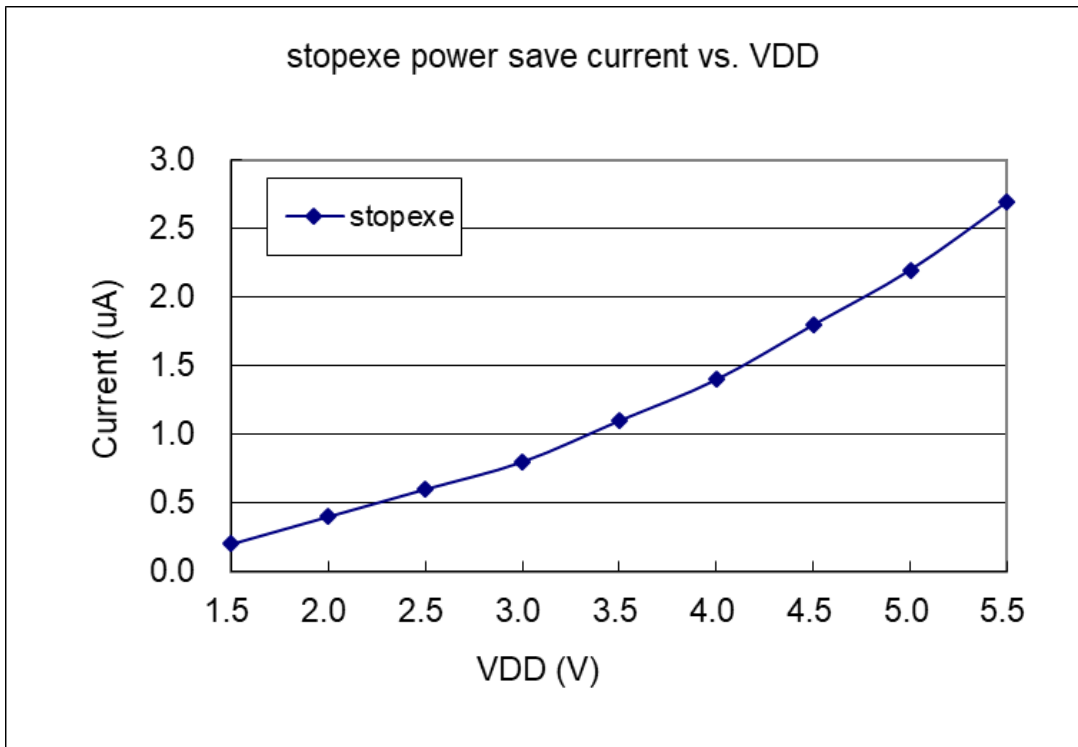
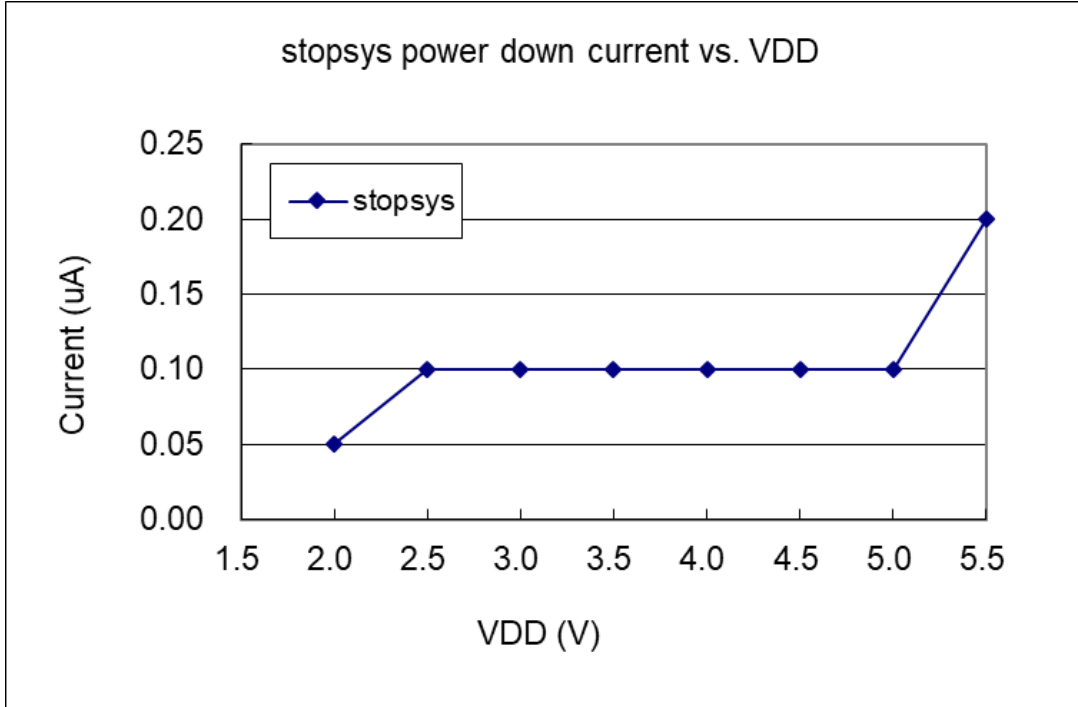

## 5. Functional Description

### 5.1. Program Memory – OTP

The OTP (One Time Programmable) program memory is used to store the program instructions to be executed. The OTP program memory may contains the data, tables and interrupt entry. After reset, the initial address for FPP0 is 0x000. The interrupt entry is 0x010 if used, the last 16 addresses are reserved for system using, like checksum, serial number, etc. The OTP program memory for PMS15B/PMS150G is 0.5KW/1KW that is partitioned as Table 1. The OTP memory from address 0x3F0 to 0x3FF is for system using, address space from 0x001 to 0x00F and from 0x011 to 0x3EF is user program space.

| Address | Function                      |
|---------|-------------------------------|
| 0x000   | FPP0 reset – goto instruction |
| 0x001   | User program                  |
| •       | •                             |
| •       | •                             |
| 0x00F   | User program                  |
| 0x010   | Interrupt entry address       |
| 0x011   | User program                  |
| •       | •                             |
| 0x1FF   | User program                  |
| 0x200   | User program                  |
| •       | •(Not for PMS15B)             |
| 0x3EF   | User program                  |
| 0x3F0   | System Using                  |
| •       | •                             |
| 0x3FF   | System Using                  |

Table 1: Program Memory Organization

### 5.2. Boot Procedure

POR (Power-On-Reset) is used to reset PMS15B/PMS150G when power up, the boot up options can be selected as fast or slow, time for fast boot-up is about 32 ILRC clock cycles and 2048 ILRC clock cycles for slow boot-up. Customer must ensure the stability of supply voltage after power up no matter which option is chosen, the power up sequence is shown in the Fig. 1 and  $t_{SBP}$  is the boot-up time.

Please noted, during Power-On-Reset, the  $V_{DD}$  must go higher than  $V_{POR}$  to boot-up the MCU.

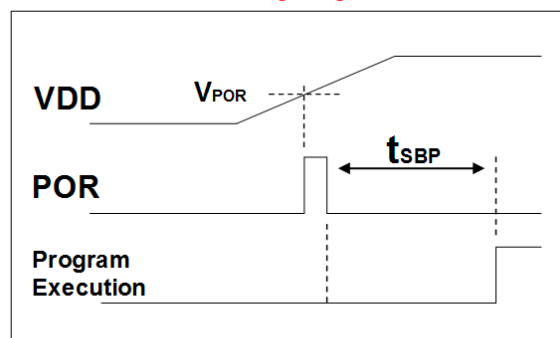

Boot up from Power-On Reset

Fig. 1: Power Up Sequence

### 5.2.1. Timing charts for reset conditions

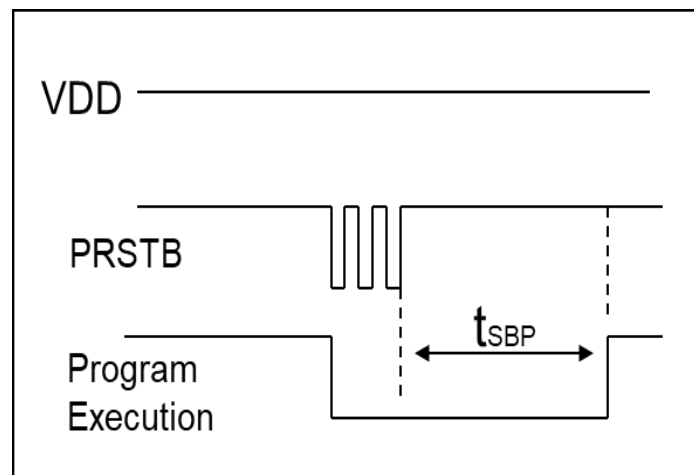
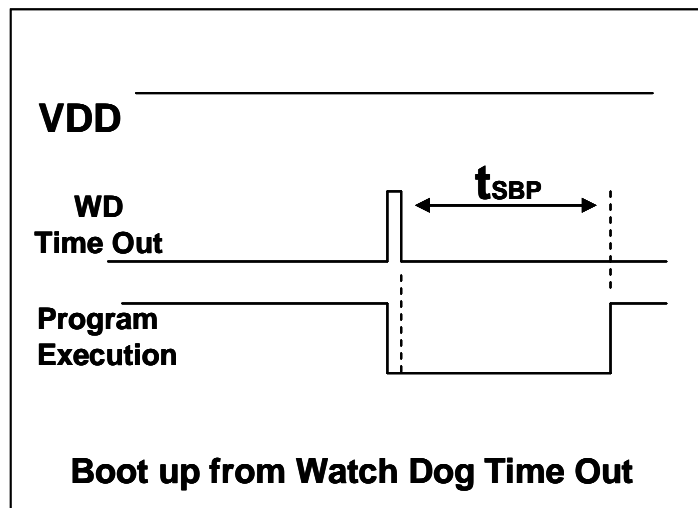
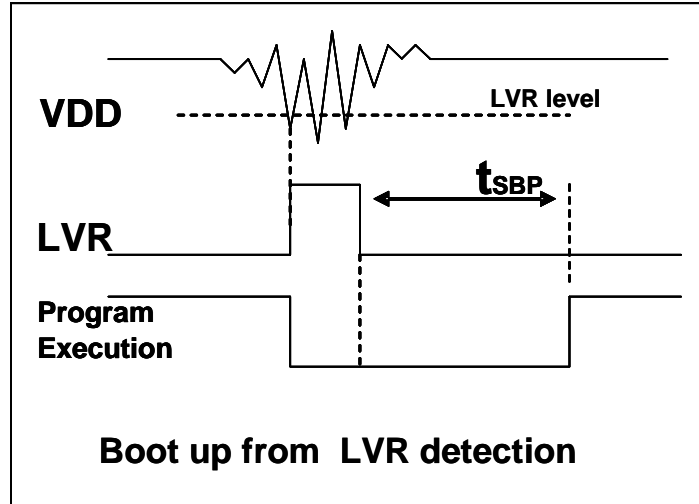

### 5.3. Data Memory – SRAM

The access of data memory can be byte or bit operation. Besides data storage, the SRAM data memory is also served as data pointer of indirect access method and the stack memory.

The stack memory is defined in the data memory. The stack pointer is defined in the stack pointer register; the depth of stack memory of each processing unit is defined by the user. The arrangement of stack memory fully flexible and can be dynamically adjusted by the user.

For indirect memory access mechanism, the data memory is used as the data pointer to address the data byte. All the data memory could be the data pointer; it's quite flexible and useful to do the indirect memory access. All the 64 bytes data memory of PMS15B/PMS150G can be accessed by indirect access mechanism.

### 5.4. Oscillator and clock

There are two oscillator circuits provided by PMS15B/PMS150G: internal high RC oscillator (IHRC) and internal low RC oscillator (ILRC), and these two oscillators are enabled or disabled by registers `clkmd.4` and `clkmd.2` independently. User can choose one of these two oscillators as system clock source and use ***clkmd*** register to target the desired frequency as system clock to meet different application.

| Oscillator Module | Enable/Disable       |
|-------------------|----------------------|
| IHRC              | <code>clkmd.4</code> |
| ILRC              | <code>clkmd.2</code> |

#### 5.4.1. Internal High RC oscillator and Internal Low RC oscillator

After boot-up, the IHRC and ILRC oscillators are enabled. The frequency of IHRC can be calibrated to eliminate process variation by ***ihrcr*** register; normally it is calibrated to 16MHz. The frequency deviation can be within 2% normally after calibration and it still drifts slightly with supply voltage and operating temperature. Please refer to the measurement chart for IHRC frequency verse  $V_{DD}$  and IHRC frequency verse temperature.

The frequency of ILRC will vary by process, supply voltage and temperature, please refer to DC specification and do not use for accurate timing application.

#### 5.4.2. IHRC calibration

The IHRC frequency may be different chip by chip due to manufacturing variation, PMS15B/PMS150G provide the IHRC frequency calibration to eliminate this variation, and this function can be selected when compiling user's program and the command will be inserted into user's program automatically. The calibration command is shown as below:

```
.ADJUST_IC      SYSCLK=IHRC/(p1), IHRC=(p2)MHz, VDD=(p3)V
```

Where,

**p1**=2, 4, 8, 16, 32; In order to provide different system clock.

**p2**=14 ~ 18; In order to calibrate the chip to different frequency, 16MHz is the usually one.

**p3**=2.2 ~ 5.5; In order to calibrate the chip under different supply voltage.

### 5.4.3. IHRC Frequency Calibration and System Clock

During compiling the user program, the options for IHRC calibration and system clock are shown as Table 2:

| SYSCLK          | CLKMD             | IHRCR      | Description                                    |
|-----------------|-------------------|------------|--|
| ○ Set IHRC / 2  | = 34h (IHRC / 2)  | Calibrated | IHRC calibrated to 16MHz, CLK=8MHz (IHRC/2)    |
| ○ Set IHRC / 4  | = 14h (IHRC / 4)  | Calibrated | IHRC calibrated to 16MHz, CLK=4MHz (IHRC/4)    |
| ○ Set IHRC / 8  | = 3Ch (IHRC / 8)  | Calibrated | IHRC calibrated to 16MHz, CLK=2MHz (IHRC/8)    |
| ○ Set IHRC / 16 | = 1Ch (IHRC / 16) | Calibrated | IHRC calibrated to 16MHz, CLK=1MHz (IHRC/16)   |
| ○ Set IHRC / 32 | = 7Ch (IHRC / 32) | Calibrated | IHRC calibrated to 16MHz, CLK=0.5MHz (IHRC/32) |
| ○ Set ILRC      | = E4h (ILRC / 1)  | Calibrated | IHRC calibrated to 16MHz, CLK=ILRC             |
| ○ Disable       | No change         | No Change  | IHRC not calibrated, CLK not changed           |

Table 2: Options for IHRC Frequency Calibration

Usually, `.ADJUST_IC` will be the first command after boot up, in order to set the target operating frequency whenever starting the system. The program code for IHRC frequency calibration is executed only one time that occurs in writing the codes into OTP memory; after then, it will not be executed again. If the different option for IHRC calibration is chosen, the system status is also different after boot. The following shows the status of PMS15B/PMS150G for different option:

- (1) `.ADJUST_IC`    `SYSCLK=IHRC/8, IHRC=16MHz, VDD=2.5V`  
 After boot, `CLKMD = 0x3C`:
  - ◆ IHRC frequency is calibrated to 16MHz@V<sub>DD</sub>=2.5V and IHRC module is enabled
  - ◆ System CLK = IHRC/8 = 2MHz
  - ◆ Watchdog timer is disabled, ILRC is enabled, PA5 is in input mode
  
- (2) `.ADJUST_IC`    `SYSCLK=IHRC/16, IHRC=16MHz, VDD=2.2V`  
 After boot, `CLKMD = 0x1C`:
  - ◆ IHRC frequency is calibrated to 16MHz@V<sub>DD</sub>=2.2V and IHRC module is enabled
  - ◆ System CLK = IHRC/16 = 1MHz
  - ◆ Watchdog timer is disabled, ILRC is enabled, PA5 is in input mode
  
- (3) `.ADJUST_IC`    `SYSCLK=IHRC/32, IHRC=16MHz, VDD=5V`  
 After boot, `CLKMD = 0x7C`:
  - ◆ IHRC frequency is calibrated to 16MHz@V<sub>DD</sub>=5V and IHRC module is enabled
  - ◆ System CLK = IHRC/32 = 500KHz
  - ◆ Watchdog timer is disabled, ILRC is enabled, PA5 is in input mode
  
- (4) `.ADJUST_IC`    `SYSCLK=ILRC, IHRC=16MHz, VDD=5V`  
 After boot, `CLKMD = 0XE4`:
  - ◆ IHRC frequency is calibrated to 16MHz@V<sub>DD</sub>=5V and IHRC module is disabled
  - ◆ System CLK = ILRC
  - ◆ Watchdog timer is disabled, ILRC is enabled, PA5 is input mode
  
- (5) `.ADJUST_IC` `DISABLE`  
 After boot, `CLKMD` is not changed (Do nothing):
  - ◆ IHRC is not calibrated.
  - ◆ System CLK = ILRC or IHRC/64 (by Boot-up\_Time)
  - ◆ Watchdog timer is enabled, ILRC is enabled, PA5 is in input mode

### 5.4.4. System Clock and LVR levels

The clock source of system clock comes from IHRC or ILRC, the hardware diagram of system clock in the PMS15B/PMS150G is shown as Fig. 2.

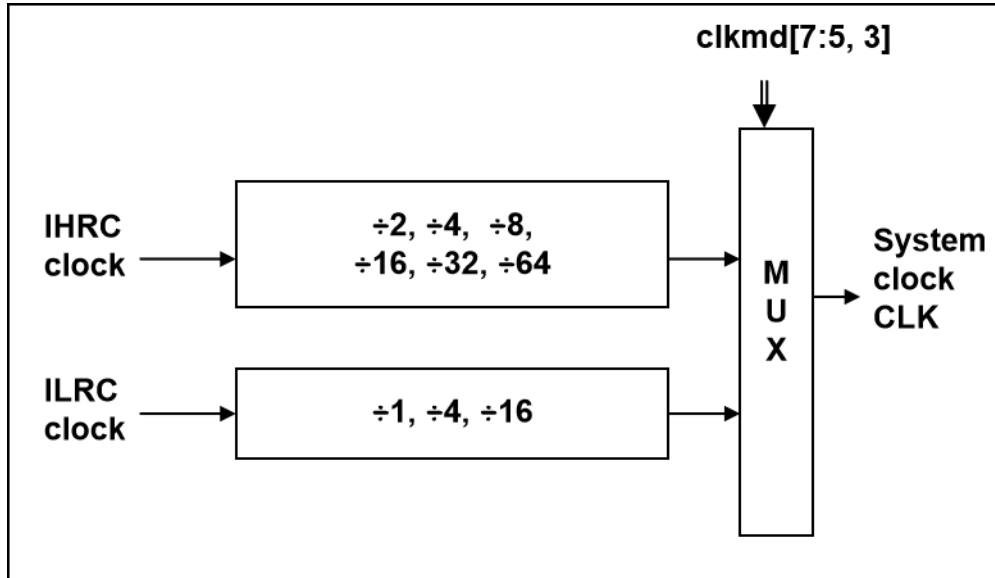

Fig. 2: Options of System Clock

User can choose different operating system clock depends on its requirement; the selected operating system clock should be combined with supply voltage and LVR level to make system stable. The LVR level will be selected during compilation. Please refer to Section 4.1.



### 5.4.5. System Clock Switching

After IHRC calibration, user may want to switch system clock to a new frequency or may switch system clock at any time to optimize the system performance and power consumption. Basically, the system clock of PMS15B/PMS150G can be switched among IHRC and ILRC by setting the **clkmd** register at any time; system clock will be the new one after writing to **clkmd** register immediately. Please notice that the original clock module can NOT be turned off at the same time as writing command to **clkmd** register. The examples are shown as below and more information about clock switching, please refer to the “Help” -> “Application Note” -> “IC Introduction” -> “Register Introduction” -> CLKMD”.

#### Case 1: Switching system clock from ILRC to IHRC/16

```

...                                     // system clock is ILRC
CLKMD.4      = 1;                       // turn on IHRC first to improve anti-interference ability
CLKMD        = 0x14;                     // switch to IHRC/16, ILRC CAN NOT be disabled here
// CLKMD.2    = 0;                       // if need, ILRC CAN be disabled at this time
...

```

#### Case 2: Switching system clock from IHRC/16 to ILRC

```

...                                     // system clock is IHRC/16
CLKMD        = 0xF4;                     // switch to ILRC, IHRC CAN NOT be disabled here
CLKMD.4      = 0;                       // IHRC CAN be disabled at this time
...

```

#### Case 3: Switching system clock from IHRC/8 to IHRC/16

```

...                                     // system clock is IHRC/8, ILRC is enabled here
CLKMD        = 0X14;                     // switch to IHRC/16
...

```

#### Case 4: System may hang if it is to switch clock and turn off original oscillator at the same time

```

...                                     // system clock is ILRC
CLKMD        = 0x30;                     // CAN NOT switch clock from ILRC to IHRC/16 and
                                         // turn off ILRC oscillator at the same time

```

### 5.5. Comparator

One hardware comparator is built inside the PMS15B/PMS150G; Fig. 3 shows its hardware diagram. It can compare signals between two pins or with either internal reference voltage  $V_{\text{internal R}}$  or internal bandgap reference voltage. The two signals to be compared, one is the plus input and the other one is the minus input. For the minus input of comparator can be PA3, PA4, Internal bandgap 1.20V, PA6, PA7 or  $V_{\text{internal R}}$  selected by bit [3:1] of gpcc register, and the plus input of comparator can be PA4 or  $V_{\text{internal R}}$  selected by bit 0 of gpcc register.

The comparator result can be selected through gpcs.7 to forcibly output to PA0 whatever it is input or output state. It can be a direct output, or sampled by Timer2 clock (TM2\_CLK) which comes from Timer2 module through gpcc.5. The output polarity can be also inverted by setting gpcc.4 register, the comparator output can be used to request interrupt service or read through gpcc.6.

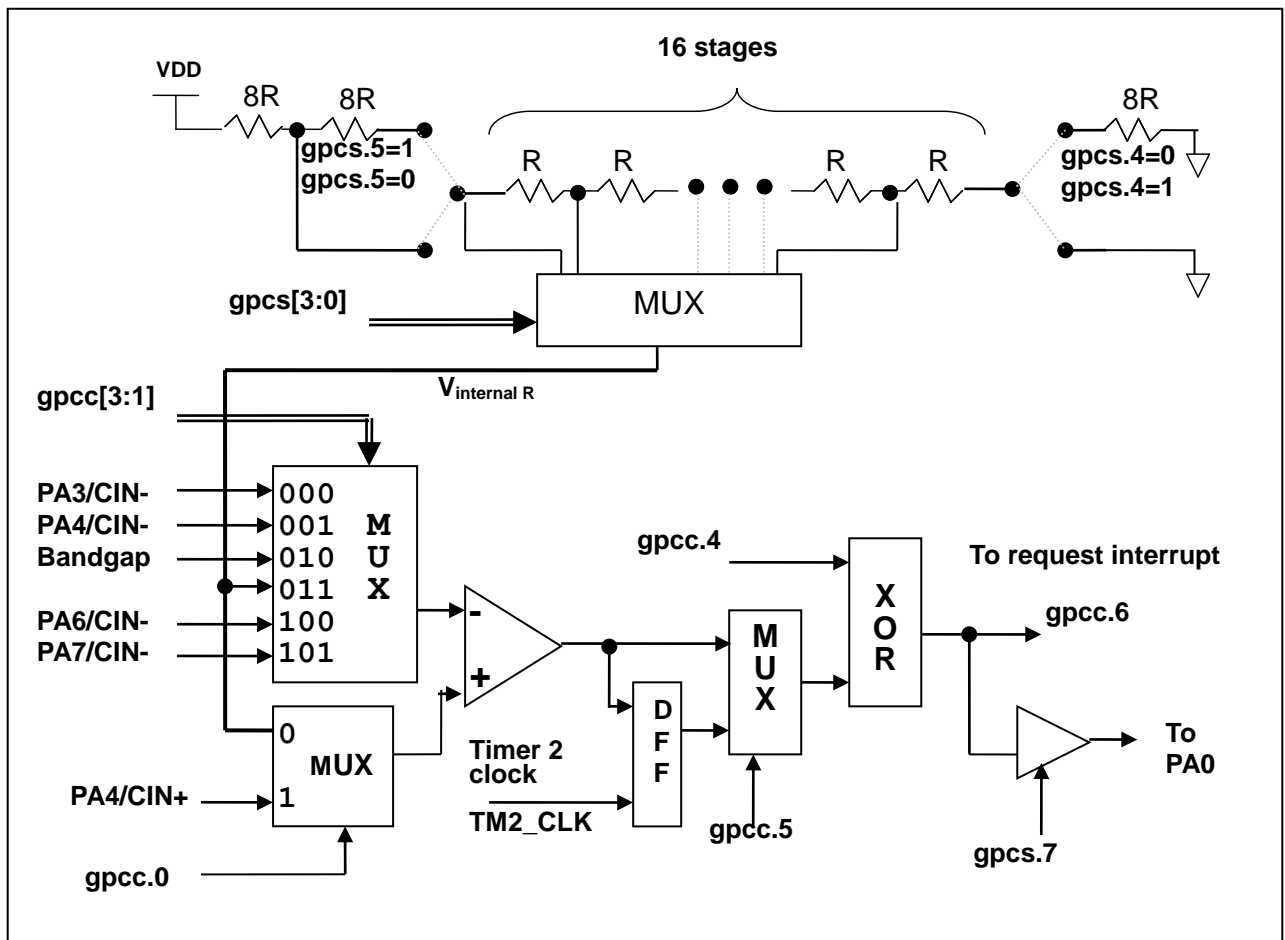

Fig. 3: Hardware diagram of comparator

### 5.5.1. Internal reference voltage ( $V_{\text{internal R}}$ )

The internal reference voltage  $V_{\text{internal R}}$  is built by series resistance to provide different level of reference voltage, bit 4 and bit 5 of gpcs register are used to select the maximum and minimum values of  $V_{\text{internal R}}$  and bit [3:0] of gpcs register are used to select one of the voltage level which is divided-by-16 from the defined maximum level to minimum level. Fig. 4 to Fig. 7 shows four conditions to have different reference voltage  $V_{\text{internal R}}$ . By setting the gpcs register, the internal reference voltage  $V_{\text{internal R}}$  can be ranged from  $(1/32)*V_{\text{DD}}$  to  $(3/4)*V_{\text{DD}}$ .

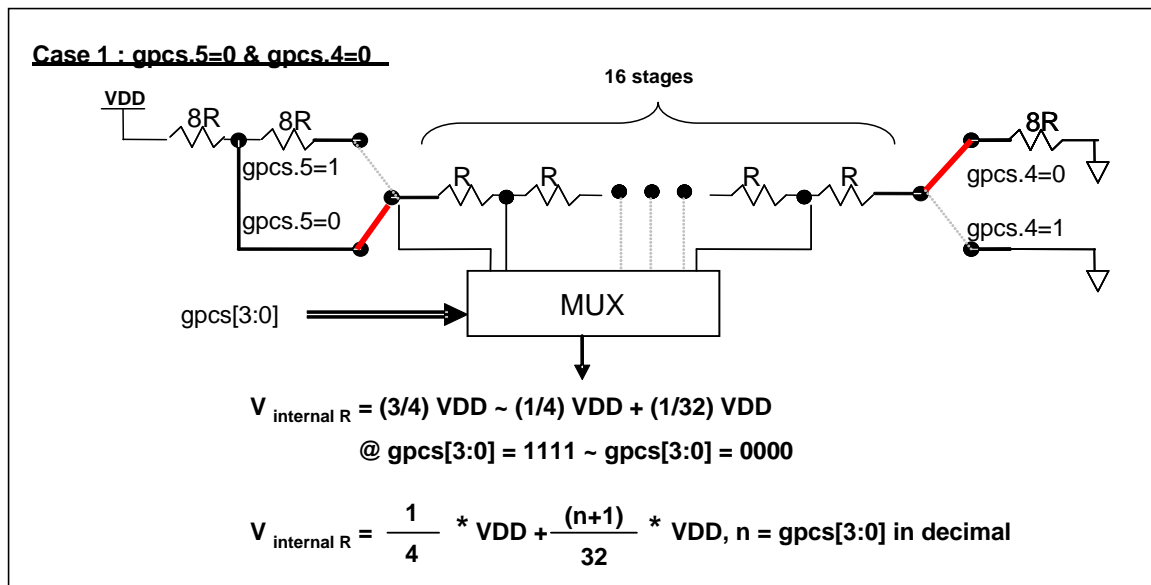

Fig. 4:  $V_{\text{internal R}}$  hardware connection if gpcs.5=0 and gpcs.4=0

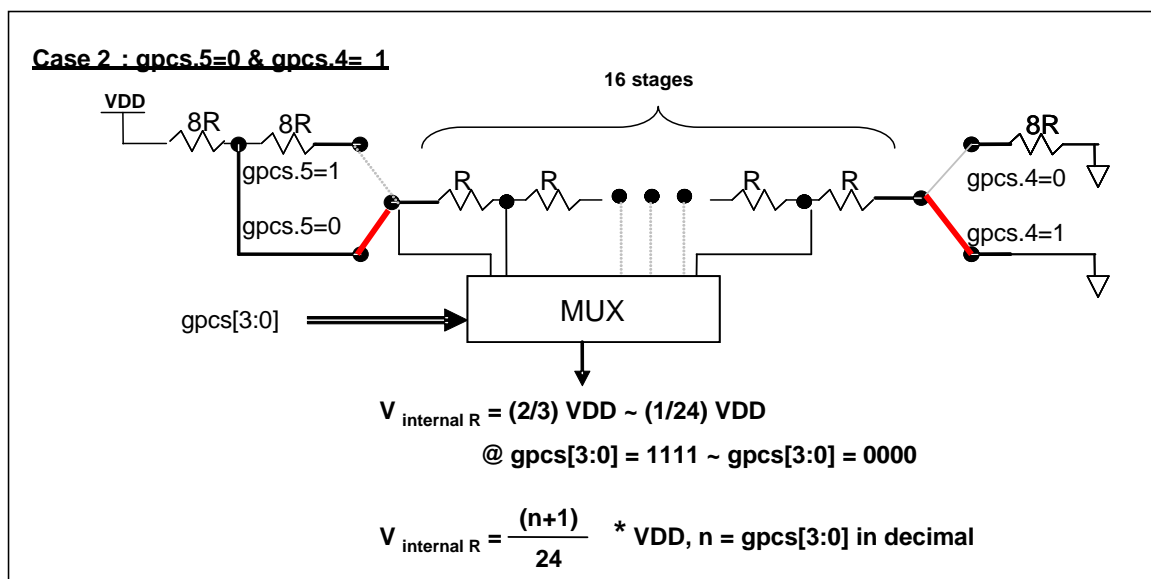

Fig. 5:  $V_{\text{internal R}}$  hardware connection if gpcs.5=1 and gpcs.4=1

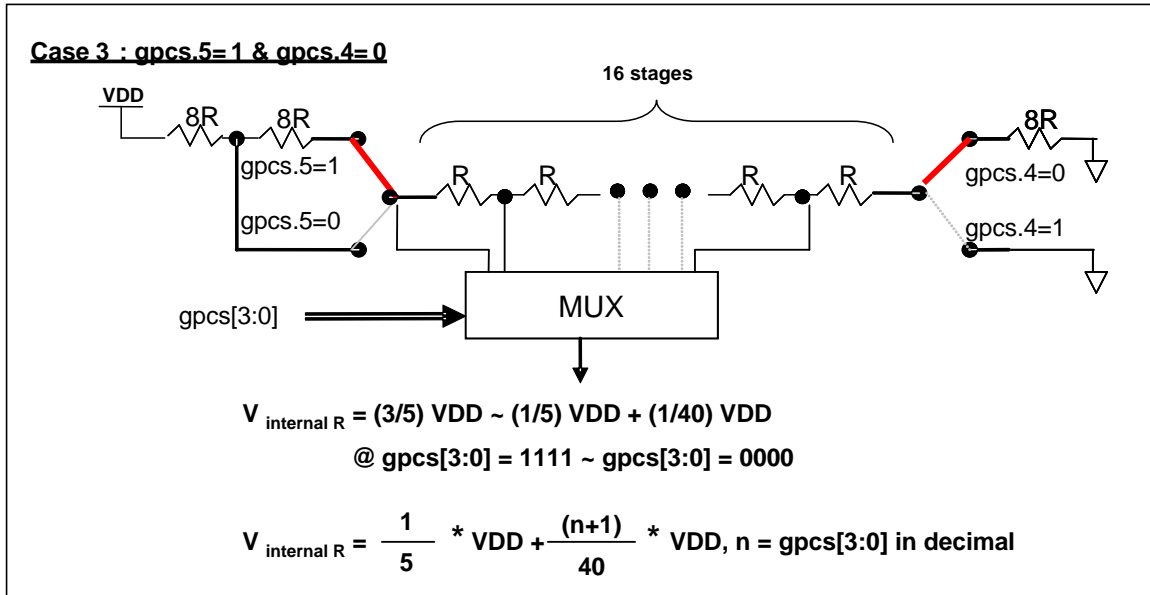

Fig.6:  $V_{\text{internal R}}$  hardware connection if gpcs.5=1 and gpcs.4=0

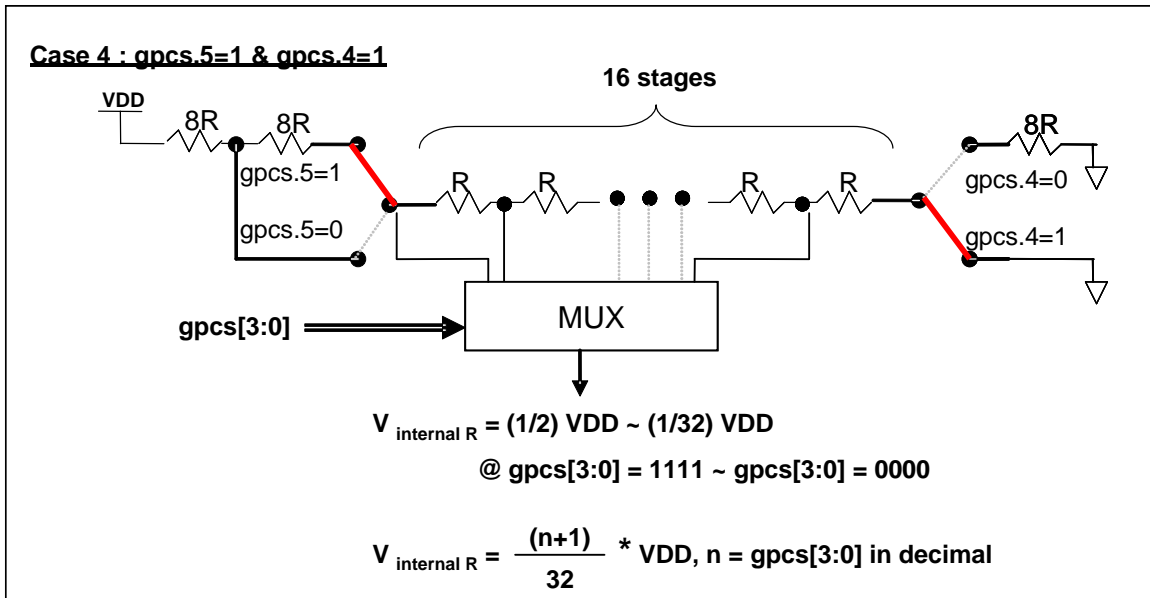

Fig.7:  $V_{\text{internal R}}$  hardware connection if gpcs.5=1 and gpcs.4=1

### 5.5.2. Using the comparator

#### Case A:

Choosing PA3 as minus input and  $V_{internal R}$  with  $(18/32)*V_{DD}$  voltage level as plus input.  $V_{internal R}$  is configured as the above Figure “gpcs[5:4] = 2b'00” and gpcs [3:0] = 4b'1001 (n=9) to have  $V_{internal R} = (1/4)*V_{DD} + [(9+1)/32]*V_{DD} = [(9+9)/32]*V_{DD} = (18/32)*V_{DD}$ .

```
gpcs      = 0b0_0_00_1001;      //  $V_{internal R} = V_{DD}*(18/32)$ 
gpcc     = 0b1_0_0_0_000_0;    // enable comp, - input: PA3, + input:  $V_{internal R}$ 
padier   = 0bxxxx_0_xxx;      // disable PA3 digital input to prevent leakage current
```

or

```
$ GPCS    $V_{DD}*18/32;$ 
$ GPCC   Enable, N_PA3, P_R;    // - input: N_xx, + input: P_R( $V_{internal R}$ )
PADIER = 0bxxxx_0_xxx;
```

#### Case B:

Choosing  $V_{internal R}$  as minus input with  $(22/40)*V_{DD}$  voltage level and PA4 as plus input, the comparator result will be inversed and then output to PA0.  $V_{internal R}$  is configured as the above Figure “gpcs[5:4] = 2b'10” and gpcs [3:0] = 4b'1101 (n=13) to have  $V_{internal R} = (1/5)*V_{DD} + [(13+1)/40]*V_{DD} = [(13+9)/40]*V_{DD} = (22/40)*V_{DD}$ .

```
gpcs      = 0b1_0_10_1101;      // output to PA0,  $V_{internal R} = V_{DD}*(22/40)$ 
gpcc     = 0b1_0_0_1_011_1;    // Inverse output, - input:  $V_{internal R}$ , + input: PA4
padier   = 0bxxx_0_xxxx;      // disable PA4 digital input to prevent leakage current
```

or

```
$ GPCS   Output,  $V_{DD}*22/40;$ 
$ GPCC   Enable, Inverse, N_R, P_PA4; // - input: N_R( $V_{internal R}$ ), + input: P_xx
PADIER = 0bxxx_0_xxxx;
```

Note: When selecting output to PA0 output, GPCS will affect the PA3 output function in ICE. Though the IC is fine, be careful to avoid this error during emulation.

### 5.5.3. Using the comparator and bandgap 1.20V

The internal bandgap module provides a stable 1.20V output, and it can be used to measure the external supply voltage level. The bandgap 1.20V is selected as minus input of comparator and  $V_{\text{internal R}}$  is selected as plus input, the supply voltage of  $V_{\text{internal R}}$  is VDD, the VDD voltage level can be detected by adjusting the voltage level of  $V_{\text{internal R}}$  to compare with bandgap. If N (gpscs[3:0] in decimal) is the number to let  $V_{\text{internal R}}$  closest to bandgap 1.20 volt, the supply voltage VDD can be calculated by using the following equations:

For using Case 1:  $V_{\text{DD}} = [ 32 / (N+9) ] * 1.20 \text{ volt ;}$

For using Case 2:  $V_{\text{DD}} = [ 24 / (N+1) ] * 1.20 \text{ volt ;}$

For using Case 3:  $V_{\text{DD}} = [ 40 / (N+9) ] * 1.20 \text{ volt ;}$

For using Case 4:  $V_{\text{DD}} = [ 32 / (N+1) ] * 1.20 \text{ volt ;}$

#### Case 1:

```

$ GPCS  VDD*12/40;           // 4.0V * 12/40 = 1.2V
$ GPCC  Enable, BANDGAP, P_R; // - input: BANDGAP, + input: P_R(Vinternal R)
....
if (GPC_Out)                 // or GPCC.6
{                             // when VDD > 4V
}
else
{                             // when VDD < 4V
}

```

### 5.6. 16-bit Timer (Timer16)

PMS15B/PMS150G provide a 16-bit hardware timer (Timer16) and its clock source may come from system clock (CLK), internal high RC oscillator (IHRC), internal low RC oscillator (ILRC), PA0 or PA4. Before sending clock to the 16-bit counter, a pre-scaling logic with divided-by-1, 4, 16 or 64 is selectable for wide range counting. The 16-bit counter performs up-counting operation only, the counter initial values can be stored from data memory by issuing the **stt16** instruction and the counting values can be loaded to data memory by issuing the **ldt16** instruction. The interrupt request from Timer16 will be triggered by the selected bit which comes from bit[15:8] of this 16-bit counter, rising edge or falling edge can be optional chosen by register **intgs.4**. The hardware diagram of Timer16 is shown as Fig. 8.

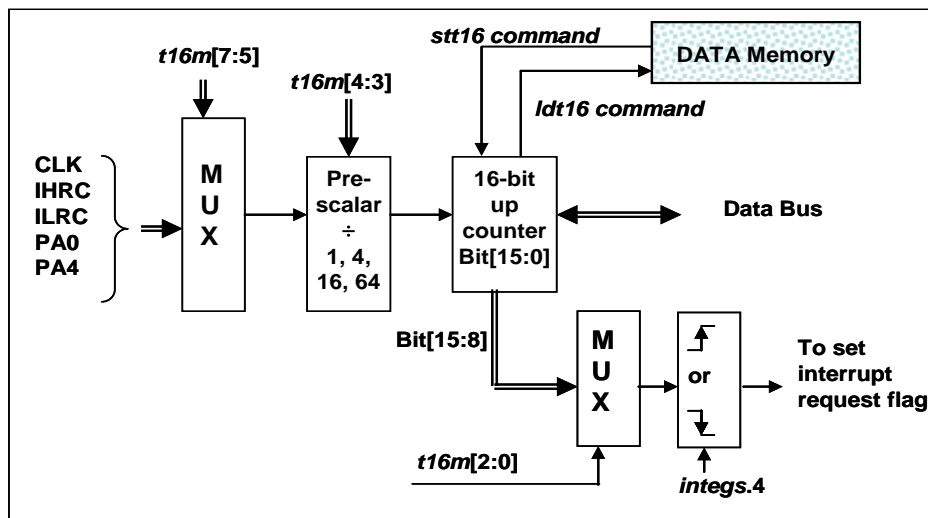

Fig. 8: Hardware diagram of Timer16

When using the Timer16, the syntax for Timer16 has been defined in the .INC file. There are three parameters to define the Timer16 using; 1<sup>st</sup> parameter is used to define the clock source of Timer16, 2<sup>nd</sup> parameter is used to define the pre-scaler and the 3<sup>rd</sup> one is to define the interrupt source.

```

T16M   IO_RW  0x06
$ 7~5:   STOP, SYSCLK, X, PA4_F, IHRC, X, ILRC, PA0_F           // 1st par.
$ 4~3:   /1, /4, /16, /64                                       // 2nd par.
$ 2~0:   BIT8, BIT9, BIT10, BIT11, BIT12, BIT13, BIT14, BIT15 // 3rd par.

```

User can choose the proper parameters of T16M to meet system requirement, examples as below:

```

$ T16M   SYSCLK, /64, BIT15;
// choose (SYSCLK/64) as clock source, every 216 clock to set INTRQ.2=1
// if system clock SYSCLK = IHRC / 2 = 8 MHz
// SYSCLK/64 = 8 MHz/64 = 8 uS, about every 524 mS to generate INTRQ.2=1

$ T16M   PA0, /1, BIT8;
// choose PA0 as clock source, every 29 to generate INTRQ.2=1
// receiving every 512 times PA0 to generate INTRQ.2=1

$ T16M   STOP;
// stop Timer16 counting

```

### 5.7. 8-bit timer (Timer2) with PWM generation

One 8-bit hardware timer (Timer2/TM2) with PWM generation is implemented in the PMS15B/PMS150G. Please refer to Fig. 9 shown its hardware diagram, the clock sources of Timer2 may come from system clock, internal high RC oscillator (IHRC) or, internal low RC oscillator (ILRC), PA0 or PA4. Bit[7:4] of register tm2c are used to select the clock source of Timer2. Please notice that if IHRC is selected for Timer2 clock source, the clock sent to Timer2 will keep running when using ICE in halt state. The output of Timer2 can be selected through tm2c[3:2] to output to PA3 or PA4. It will be a forcibly output whatever the PX.x is in input or output state. A clock pre-scaling module is provided with divided-by-1, 4, 16, and 64 options, controlled by bit [6:5] of tm2s register; one scaling module with divided-by-1~32 is also provided and controlled by bit [4:0] of tm2s register. In conjunction of pre-scaling function and scaling function, the frequency of Timer2 clock (TM2\_CLK) can be wide range and flexible.

The Timer2 counter performs 8-bit up-counting operation only; the counter values can be set or read back by tm2ct register. The 8-bit counter will be clear to zero automatically when its values reach for upper bound register, the upper bound register is used to define the period of timer or duty of PWM. There are two operating modes for Timer2: period mode and PWM mode; period mode is used to generate periodical output waveform or interrupt event; PWM mode is used to generate PWM output waveform with optional 6-bit or 8-bit PWM resolution, Fig. 10 shows the timing diagram of Timer2 for both period mode and PWM mode.

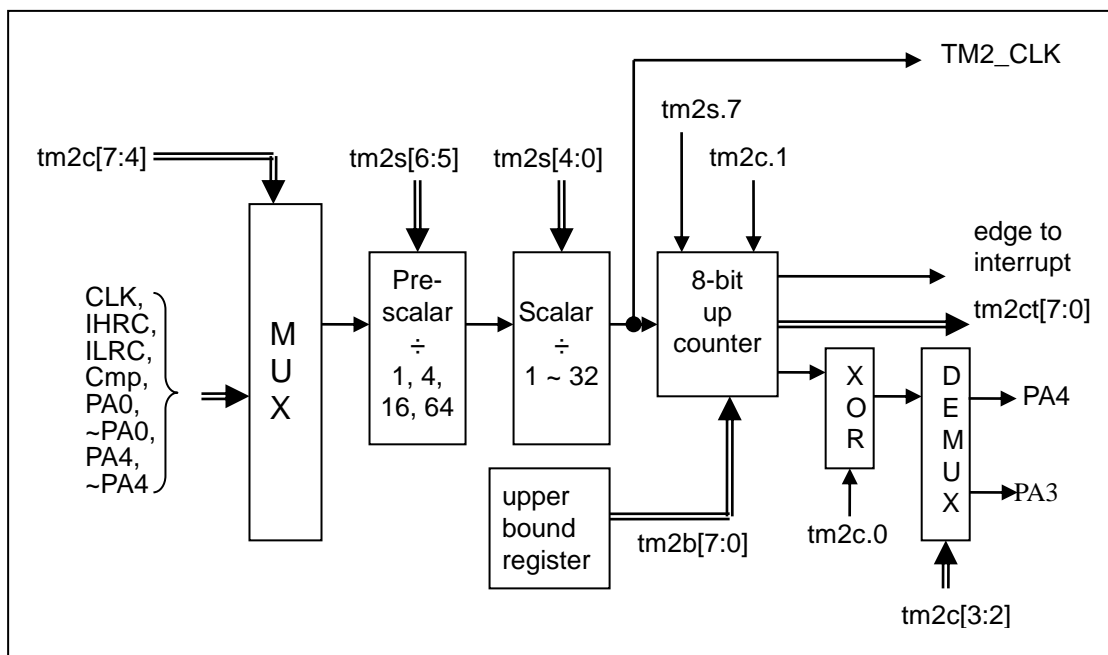

Fig. 9: Timer2 hardware diagram



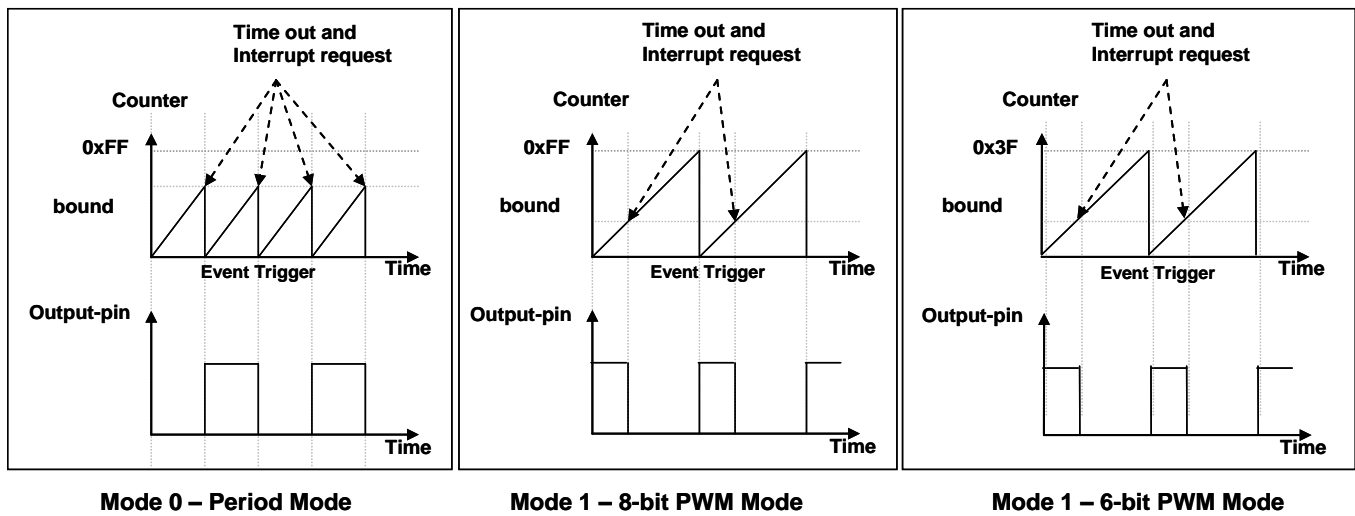

Fig. 10: Timing diagram of Timer2 in period mode and PWM mode (tm2c.1=1)

### 5.7.1. Using the Timer2 to generate periodical waveform

If periodical mode is selected, the duty cycle of output is always 50%; its frequency can be summarized as below:

$$\text{Frequency of Output} = Y \div [2 \times (K+1) \times S1 \times (S2+1)]$$

Where,  $Y = \text{tm2c}[7:4]$  : frequency of selected clock source  
 $K = \text{tm2b}[7:0]$  : bound register in decimal  
 $S1 = \text{tm2s}[6:5]$  : pre-scalar ( $S1=1, 4, 16, 64$ )  
 $S2 = \text{tm2s}[4:0]$  : scalar register in decimal ( $S2=0 \sim 31$ )

#### Example 1:

tm2c = 0b0001\_1000, Y=2MHz  
 tm2b = 0b0111\_1111, K=127  
 tm2s = 0b0\_00\_00000, S1=1, S2=0  
 → frequency of output =  $2\text{MHz} \div [2 \times (127+1) \times 1 \times (0+1)] = 7.8\text{kHz}$

#### Example 2:

tm2c = 0b0001\_1000, Y=2MHz  
 tm2b = 0b0111\_1111, K=127  
 tm2s[7:0] = 0b0\_10\_11111, S1=16, S2 = 31  
 → frequency =  $2\text{MHz} \div (2 \times (127+1) \times 16 \times (31+1)) = 15.25\text{Hz}$

#### Example 3:

tm2c = 0b0001\_1000, Y=2MHz  
 tm2b = 0b0000\_1111, K=15  
 tm2s = 0b0\_00\_00000, S1=1, S2=0  
 → frequency =  $2\text{MHz} \div (2 \times (15+1) \times 1 \times (0+1)) = 62.5\text{kHz}$

#### Example 4:

tm2c = 0b0001\_1000, Y=2MHz  
 tm2b = 0b0000\_0001, K=1  
 tm2s = 0b0\_00\_00000, S1=1, S2=0  
 → frequency =  $2\text{MHz} \div (2 \times (1+1) \times 1 \times (0+1)) = 500\text{kHz}$

The sample program for using the Timer2 to generate periodical waveform to PA3 is shown as below:

```
void FPPA0 (void)
{
    . ADJUST_IC    SYSCLK=IHRC/8, IHRC=16MHz, VDD=5V
    ...
    tm2ct = 0x00;
    tm2b = 0x7f;
    tm2s = 0b0_00_00001;           // 8-bit PWM, pre-scalar = 1, scalar = 2
    tm2c = 0b0001_10_0_0;         // system clock, output=PA3, period mode
    while(1)
    {
        nop;
    }
}
```

### 5.7.2. Using the Timer2 to generate 8-bit PWM waveform

If 8-bit PWM mode is selected, it should set tm2c[1]=1 and tm2s[7]=0, the frequency and duty cycle of output waveform can be summarized as below:

$$\text{Frequency of Output} = Y \div [256 \times S1 \times (S2+1) ]$$

$$\text{Duty of Output} = [( K+1 ) \div 256] \times 100\%$$

Where, Y = tm2c[7:4] : frequency of selected clock source

K = tm2b[7:0] : bound register in decimal

S1= tm2s[6:5] : pre-scalar (S1=1, 4, 16, 64)

S2 = tm2s[4:0] : scalar register in decimal (S2=0 ~ 31)

#### Example 1:

tm2c = 0b0001\_1010, Y=2MHz

tm2b = 0b0111\_1111, K=127

tm2s = 0b0\_00\_00000, S1=1, S2=0

→ frequency of output = 2MHz ÷ ( 256 × 1 × (0+1) ) = 7.8kHz

→ duty of output = [(127+1) ÷ 256] × 100% = 50%

#### Example 2:

tm2c = 0b0001\_1010, Y=2MHz

tm2b = 0b0111\_1111, K=127

tm2s = 0b0\_10\_11111, S1=16, S2=31

→ frequency of output = 2MHz ÷ ( 256 × 16 × (31+1) ) = 15.25Hz

→ duty of output = [(127+1) ÷ 256] × 100% = 50%

### Example 3:

tm2c = 0b0001\_1010, Y=2MHz

tm2b = 0b1111\_1111, K=255

tm2s = 0b0\_00\_00000, S1=1, S2=0

→ frequency of output =  $2\text{MHz} \div (256 \times 1 \times (0+1)) = 7.8\text{kHz}$

→ duty of output =  $[(255+1) \div 256] \times 100\% = 100\%$

### Example 4:

tm2c = 0b0001\_1010, Y=2MHz

tm2b = 0b0000\_1001, K = 9

tm2s = 0b0\_00\_00000, S1=1, S2=0

→ frequency of output =  $2\text{MHz} \div (256 \times 1 \times (0+1)) = 7.8\text{kHz}$

→ duty of output =  $[(9+1) \div 256] \times 100\% = 3.9\%$

The sample program for using the Timer2 to generate PWM waveform from PA3 is shown as below:

```

void    FPPA0 (void)
{
    .ADJUST_IC    SYSCLK=IHRC/8, IHRC=16MHz, VDD=5V
    wdreset;
    tm2ct = 0x00;
    tm2b = 0x7f;
    tm2s = 0b0_00_00001;           // 8-bit PWM, pre-scalar = 1, scalar = 2
    tm2c = 0b0001_10_1_0;         // system clock, output=PA3, PWM mode
    while(1)
    {
        nop;
    }
}

```

### 5.7.3. Using the Timer2 to generate 6-bit PWM waveform

If 6-bit PWM mode is selected, it should set tm2c[1]=1 and tm2s[7]=1, the frequency and duty cycle of output waveform can be summarized as below:

$$\text{Frequency of Output} = Y \div [64 \times S1 \times (S2+1) ]$$

$$\text{Duty of Output} = [( K + 1 ) \div 64] \times 100\%$$

Where, tm2c[7:4] = Y : frequency of selected clock source

tm2b[7:0] = K : bound register in decimal

tm2s[6:5] = S1 : pre-scalar (S1=1, 4, 16, 64)

tm2s[4:0] = S2 : scalar register in decimal (S2=0 ~ 31)

#### Example 1:

tm2c = 0b0001\_1010, Y=2MHz

tm2b = 0b0001\_1111, K=31

tm2s = 0b1\_00\_00000, S1=1, S2=0

→ frequency of output = 2MHz ÷ ( 64 × 1 × (0+1) ) = 31.25kHz

→ duty = [(31+1) ÷ 64] × 100% = 50%

#### Example 2:

tm2c = 0b0001\_1010, Y=2MHz

tm2b = 0b0001\_1111, K=31

tm2s = 0b1\_11\_11111, S1=64, S2=31

→ frequency of output = 2MHz ÷ ( 64 × 64 × (31+1) ) = 15.25Hz

→ duty of output = [(31+1) ÷ 64] × 100% = 50%

#### Example 3:

tm2c = 0b0001\_1010, Y=2MHz

tm2b = 0b0011\_1111, K=63

tm2s = 0b1\_00\_00000, S1=1, S2=0

→ frequency of output = 2MHz ÷ ( 64 × 1 × (0+1) ) = 31.25kHz

→ duty of output = [(63+1) ÷ 64] × 100% = 100%

#### Example 4:

tm2c = 0b0001\_1010, Y=2MHz

tm2b = 0b0000\_0000, K=0

tm2s = 0b1\_00\_00000, S1=1, S2=0

→ frequency = 2MHz ÷ ( 64 × 1 × (0+1) ) = 31.25kHz

→ duty = [(0+1) ÷ 64] × 100% = 1.5%

### 5.8. Watchdog Timer

The watchdog timer (WDT) is a counter with clock coming from ILRC and its frequency is about 62KHz@5V. There are 4 different timeout periods of watchdog timer can be chosen by setting the *misc* register, it is:

- ◆ 256k ILRC clock period when *misc*[1:0]=11
- ◆ 64k ILRC clock period when *misc*[1:0]=10
- ◆ 16k ILRC clock period when *misc*[1:0]=01
- ◆ 8k ILRC clock period when *misc*[1:0]=00 (default)

The frequency of ILRC may drift a lot due to the variation of manufacture, supply voltage and temperature; user should reserve guard band for safe operation. WDT can be cleared by power-on-reset or by command *wdreset* at any time. When WDT is timeout, PMS15B/PMS150G will be reset to restart the program execution. The relative timing diagram of watchdog timer is shown as Fig. 11.

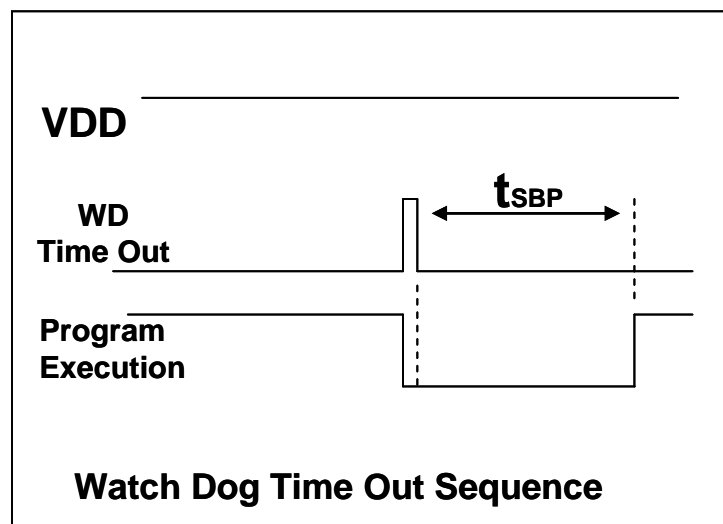

Fig. 11: Sequence of Watch Dog Time Out

### 5.9. Interrupt

There are four interrupt lines for PMS15B/PMS150G:

- ◆ External interrupt PA0
- ◆ GPC interrupt
- ◆ Timer16 interrupt
- ◆ Timer2 interrupt

Every interrupt request line has its own corresponding interrupt control bit to enable or disable it; the hardware diagram of interrupt function is shown as Fig. 12. All the interrupt request flags are set by hardware and cleared by writing *intrq* register. When the request flags are set, it can be rising edge, falling edge or both, depending on the setting of register *integs*. All the interrupt request lines are also controlled by *engint* instruction (enable global interrupt) to enable interrupt operation and *disgint* instruction (disable global interrupt) to disable it. The stack memory for interrupt is shared with data memory and its address is specified by stack register *sp*. Since the program counter is 16 bits width, the bit 0 of stack register *sp* should be kept 0. Moreover, user can use *pushaf* / *popaf* instructions to store or restore the values of *ACC* and *flag* register *to* / *from* stack memory.

Since the stack memory is shared with data memory, the stack position and level are arranged by the compiler in Mini-C project. When defining the stack level in ASM project, users should arrange their locations carefully to prevent address conflicts.

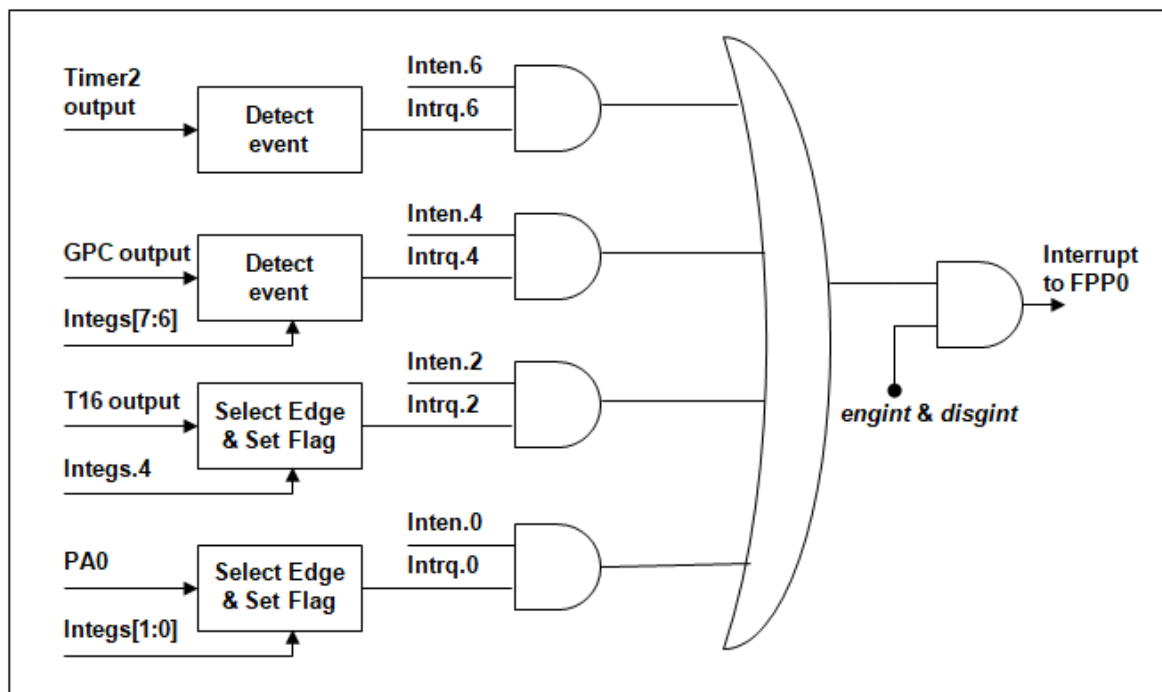

Fig. 12: Hardware diagram of Interrupt controller

Once the interrupt occurs, its operation will be:

- ◆ The program counter will be stored automatically to the stack memory specified by register *sp*.
- ◆ New *sp* will be updated to *sp+2*.
- ◆ Global interrupt will be disabled automatically.
- ◆ The next instruction will be fetched from address 0x010.

During the interrupt service routine, the interrupt source can be determined by reading the *intrq* register.

Note: Even if *INTEN=0*, *INTRQ* will be still triggered by the interrupt source.

After finishing the interrupt service routine and issuing the *reti* instruction to return back, its operation will be:

- ◆ The program counter will be restored automatically from the stack memory specified by register *sp*.
- ◆ New *sp* will be updated to *sp-2*.
- ◆ Global interrupt will be enabled automatically.
- ◆ The next instruction will be the original one before interrupt.

User must reserve enough stack memory for interrupt, two bytes stack memory for one level interrupt and four bytes for two levels interrupt. And so on, two bytes stack memory is for *pushaf*. For interrupt operation, the following sample program shows how to handle the interrupt, noticing that it needs four bytes stack memory to handle interrupt and *pushaf*.

```
void      FPPA0  (void)
{
    ...
    $ INTEN PA0;           // INTEN =1; interrupt request when PA0 level changed
    INTRQ = 0;            // clear INTRQ
    ENGINT                // global interrupt enable
    ...
    DISGINT               // global interrupt disable
    ...
}
```

```

void Interrupt (void)           // interrupt service routine
{
    PUSHAF                     // store ALU and FLAG register

    // If INTEN.PA0 will be opened and closed dynamically,
    // user can judge whether INTEN.PA0 =1 or not.
    // Example: If (INTEN.PA0 && INTRQ.PA0) {...}

    // If INTEN.PA0 is always enable,
    // user can omit the INTEN.PA0 judgement to speed up interrupt service routine.

    If (INTRQ.PA0)
    {
        // Here for PA0 interrupt service routine
        INTRQ.PA0 = 0; // Delete corresponding bit (take PA0 for example)
        ...
    }
    ...
    // X : INTRQ = 0; // It is not recommended to use INTRQ = 0 to clear all at the end of
    // the interrupt service routine.
    // It may accidentally clear out the interrupts that have just occurred
    // and are not yet processed.

    POPAF                       // restore ALU and FLAG register
}

```

### 5.10. Power-Save and Power-Down

There are three operational modes defined by hardware: ON mode, Power-Save mode and Power-Down modes. ON mode is the state of normal operation with all functions ON, Power-Save mode (“**stopexe**”) is the state to reduce operating current and CPU keeps ready to continue, Power-Down mode (“**stopsys**”) is used to save power deeply. Therefore, Power-Save mode is used in the system which needs low operating power with wake-up occasionally and Power-Down mode is used in the system which needs power down deeply with seldom wake-up. Table 3 shows the differences in oscillator modules between Power-Save mode (“**stopexe**”) and Power-Down mode (“**stopsys**”).

| Differences in oscillator modules between STOPSYS and STOPEXE |           |           |
|---|-----------|-----------|
|   | IHRC      | ILRC      |
| STOPSYS   | Stop      | Stop      |
| STOPEXE   | No Change | No Change |

Table 3: Differences in oscillator modules between STOPSYS and STOPEXE



### 5.10.1. Power-Save mode (“*stopexe*”)

Using “*stopexe*” instruction to enter the Power-Save mode, only system clock is disabled, remaining all the oscillator modules be active. For CPU, it stops executing; however, for Timer16, counter keep counting if its clock source is not the system clock. The wake-up sources for “*stopexe*” can be IO-toggle or Timer16 counts to set values when the clock source of Timer16 is IHRC or ILRC modules, or wakeup by comparator when setting *GPCC.7=1* and *GPCS.6=1* to enable the comparator wakeup function at the same time. Wake-up from input pins can be considered as a continuation of normal execution, the detail information for Power-Save mode shown below:

- IHRC oscillator modules: No change, keep active if it was enabled.
- ILRC oscillator modules: must remain enabled, need to start with ILRC when be wakening up.
- System clock: Disable, therefore, CPU stops execution.
- OTP memory is turned off.
- Timer counter: Stop counting if its clock source is system clock or the corresponding oscillator module is disabled; otherwise, it keeps counting. (The Timer contains TM16, TM2.)
- Wake-up sources:
  - a. IO toggle wake-up: IO toggling in digital input mode (*PAC* bit is 1 and *PADIER* bit is 1)
  - b. Timer wake-up: If the clock source of Timer is not the *SYSClk*, the system will be awakened when the Timer counter reaches the set value.
  - c. Comparator wake-up: It need setting *GPCC.7=1* and *GPCS.6=1* to enable the comparator wake-up function at the same time. Please note: the internal 1.20V bandgap reference voltage is not suitable for the comparator wake-up function.

The watchdog timer must be disabled before issuing the “*stopexe*” command, the example is shown as below:

```

CLKMD.En_WatchDog = 0;      // disable watchdog timer
stopexe;
....                          // power saving
Wdreset;
CLKMD.En_WatchDog = 1;      // enable watchdog timer

```

Another example shows how to use Timer16 to wake-up from “*stopexe*”:

```

$ T16M  ILRC, /1, BIT8      // Timer16 setting
...
WORD  count    = 0;
STT16  count;
stopexe;
...

```

The initial counting value of Timer16 is zero and the system will be waken up after the Timer16 counts 256 ILRC clocks.

### 5.10.2. Power-Down mode (“*stopsys*”)

Power-Down mode is the state of deeply power-saving with turning off all the oscillator modules. By using the “*stopsys*” instruction, this chip will be put on Power-Down mode directly. It is recommending to set GPCC.7=0 to disable the comparator before the command “*stopsys*”. The following shows the internal status of PMS15B/PMS150G in detail when “*stopsys*” command is issued:

- All the oscillator modules are turned off.
- OTP memory is turned off.
- The contents of SRAM and registers remain unchanged.
- Wake-up sources: IO toggle in digital input mode (PADIER bit is 1)

Wake-up from input pins can be considered as a continuation of normal execution. To minimize power consumption, all the I/O pins should be carefully manipulated before entering power-down mode. The reference sample program for power down is shown as below:

```

CMKMD = 0xF4; // Change clock from IHRC to ILRC, disable watchdog timer
CLKMD.4 = 0; // disable IHRC
...
while (1)
{
    STOPSYS; // enter power-down
    if (...) break; // if wakeup happen and check OK, then return to high speed,
    // else stay in power-down mode again.
}
CLKMD = 0x3C; // Change clock from ILRC to IHRC/8

```

### 5.10.3. Wake-up

After entering the Power-Down or Power-Save modes, the PMS15B/PMS150G can be resumed to normal operation by toggling IO pins. Wake-up from timer are available for Power-Save mode ONLY. Table 4 shows the differences in wake-up sources between STOPSYS and STOPEXE.

| Differences in wake-up sources between <i>stopsys</i> and <i>stopexe</i> |           |               |                    |
|--|-----------|---------------|--------------------|
|  | IO Toggle | Timer wake-up | Comparator wake-up |
| <i>stopsys</i>   | Yes       | No            | No                 |
| <i>stopexe</i>   | Yes       | Yes           | Yes                |

Table 4: Differences in wake-up sources between Power-Save mode and Power-Down mode

When using the IO pins to wake-up the PMS15B/PMS150G, registers *padier* should be properly set to enable the wake-up function for every corresponding pin. The time for normal wake-up is about 2048 ILRC clocks counting from wake-up event; fast wake-up can be selected to reduce the wake-up time by *misc.5* register, and the time for fast wake-up is 32 ILRC clocks from IO toggling. But the fast wake-up from *misc.5* register only worked in slow boot-up mode.

| Suspend mode                             | Wake-up mode   | Wake-up time ( $t_{WUP}$ ) from IO toggle                           |
|--|----------------|---|
| STOPEXE suspend<br>or<br>STOPSYS suspend | fast wake-up   | $32 * T_{ILRC}$ ,<br>Where $T_{ILRC}$ is the time period of ILRC    |
| STOPEXE suspend<br>or<br>STOPSYS suspend | normal wake-up | $2048 * T_{ILRC}$ ,<br>Where $T_{ILRC}$ is the clock period of ILRC |

Table 5: Differences in wake-up time between fast/normal wake-up

### 5.11. IO Pins

All the pins can be independently set into two states output or input by configuring the data registers (**pa**), control registers (**pac**), pull-high registers (**paph**) and pull-low registers (**papl**). All these pins have Schmitt-trigger input buffer and output driver with CMOS level. When it is set to output low, the pull-high/pull-low resistor is turned off automatically. When the pull-high / pull-low resistor enabled at the same time, the pull-low resistor will be turned off automatically. If user wants to read the pin state, please notice that it should be set to input mode before reading the data port; if user reads the data port when it is set to output mode, the reading data comes from data register, NOT from IO pad. As an example, Table 6 shows the configuration table of bit 0 of port A. The hardware diagram of IO buffer is also shown as Fig. 13.

| <b>pa.0</b> | <b>pac.0</b> | <b>paph.0</b> | <b>papl.0</b> | 描述  |
|-------------|--------------|---------------|---------------|---|
| X           | 0            | 0             | 0             | Input without pull-high / pull-low resistor       |
| X           | 0            | 1             | 0             | Input with pull-high resistor                     |
| X           | 0            | 0             | 1             | Input with pull-low resistor                      |
| X           | 0            | 1             | 1             | Input with pull-high resistor only                |
| 0           | 1            | X             | X             | Output low without pull-high / pull-low resistor  |
| 1           | 1            | X             | X             | Output high without pull-high / pull-low resistor |

Table 6: PA0 Configuration Table

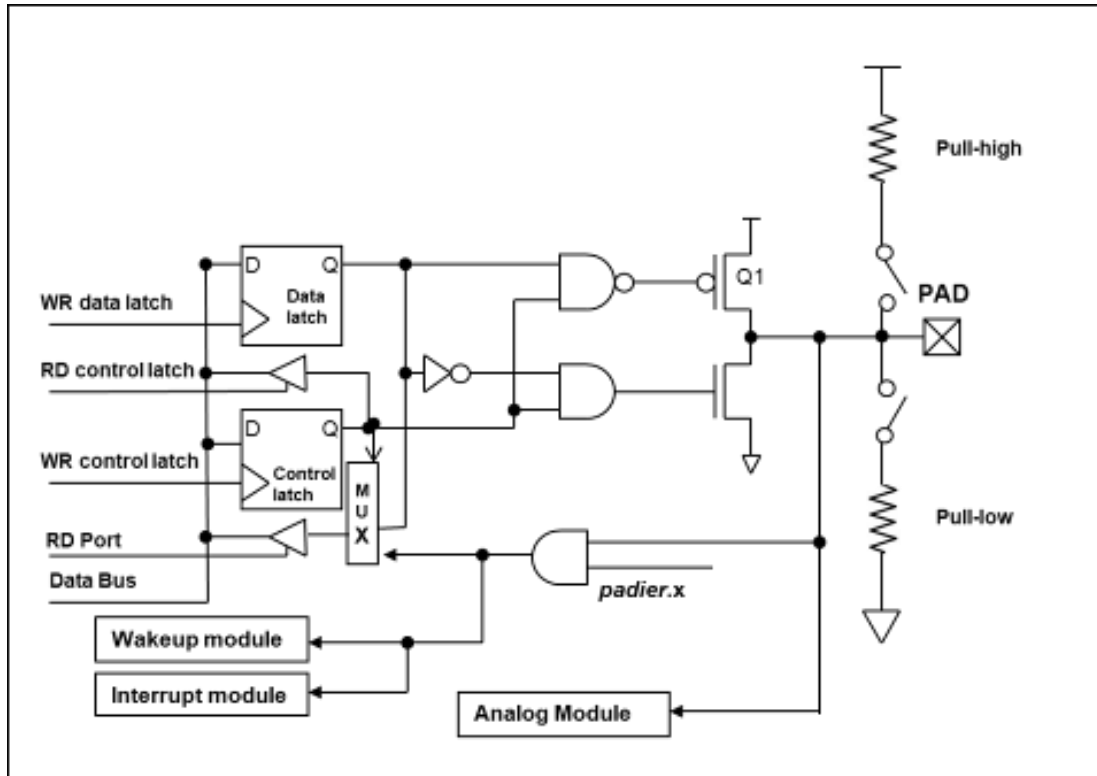

Fig. 13: Hardware diagram of IO buffer

PA5 can be set as Normal IO or Open-Drain mode through PA5\_Open\_Drain in Code Option.

Except PA5, all the IO pins have the same structure; When PMS15B/PMS150G is put in power-down or power-save mode, every pin can be used to wake-up system by toggling its state. Therefore, those pins needed to wake-up system must be set to input mode and set the corresponding bits of registers *padier* to high. The same reason, *padier.0* should be set to high when PA0 is used as external interrupt pin.

## 5.12. Reset

### 5.12.1. Reset

There are many causes to reset the PMS15A/PMS150C, once reset is asserted, most of all the registers in PMS15A/PMS150C will be set to default values, system should be restarted once abnormal cases happen, or by jumping program counter to address 0x00.

After power-up and LVR reset, the SRAM data will be kept when  $V_{DD} > V_{DR}$  (SRAM data retention voltage). However, if SRAM is cleared after power-on again, the data cannot be kept. And, the data memory is in an uncertain state when  $V_{DD} < V_{DR}$ .

The content will be kept when reset comes from PRSTB pin or WDT timeout.

### 5.12.2. LVR reset

By code option, there are many different levels of LVR for reset. Usually, user selects LVR reset level to be in conjunction with operating frequency and supply voltage.

## 6. IO Registers

### 6.1. ACC Status Flag Register (*flag*), IO address = 0x00

| Bit   | Reset | R/W | Description  |
|-------|-------|-----|--|
| 7 - 4 | -     | -   | Reserved. These four bits are "1" when read.   |
| 3     | -     | R/W | OV (Overflow). This bit is set whenever the sign operation is overflow.  |
| 2     | -     | R/W | AC (Auxiliary Carry). There are two conditions to set this bit, the first one is carry out of low nibble in addition operation, and the other one is borrow from the high nibble into low nibble in subtraction operation. |
| 1     | -     | R/W | C (Carry). There are two conditions to set this bit, the first one is carry out in addition operation, and the other one is borrow in subtraction operation. Carry is also affected by shift with carry instruction.       |
| 0     | -     | R/W | Z (Zero). This bit will be set when the result of arithmetic or logic operation is zero; Otherwise, it is cleared.   |

### 6.2. Stack Pointer Register (*sp*), IO address = 0x02

| Bit   | Reset | R/W | Description  |
|-------|-------|-----|--|
| 7 - 0 | -     | R/W | Stack Pointer Register. Read out the current stack pointer, or write to change the stack pointer. Please notice that bit 0 should be kept 0 due to program counter is 16 bits. |

### 6.3. Clock Mode Register (*clkmd*), IO address = 0x03

| Bit   | Reset | R/W | Description  |
|-------|-------|-----|--|
| 7 - 5 | 111   | R/W | System clock selection:  |
|       |       |     | Type 0, clkmd[3]=0   |
|       |       |     | 000: IHRC÷4<br>001: IHRC÷2<br>01x: reserved<br>10x: reserved<br>110: ILRC÷4<br>111: ILRC (default)                   |
|       |       |     | 000: IHRC÷16<br>001: IHRC÷8<br>010: ILRC÷16 (ICE does NOT Support.)<br>011: IHRC÷32<br>100: IHRC÷64<br>1xx: reserved |
| 4     | 1     | R/W | IHRC oscillator Enable. 0 / 1: disable / enable  |
| 3     | 0     | RW  | Clock Type Select. This bit is used to select the clock type in bit [7:5].<br>0 / 1: Type 0 / Type 1                 |
| 2     | 1     | R/W | ILRC Enable. 0 / 1: disable / enable<br>If ILRC is disabled, watchdog timer is also disabled.                        |
| 1     | 1     | R/W | Watch Dog Enable. 0 / 1: disable / enable  |
| 0     | 0     | R/W | Pin PA5/PRSTB function. 0 / 1: PA5 / PRSTB   |

### 6.4. Interrupt Enable Register (*inten*), IO address = 0x04

| Bit     | Reset | R/W | Description  |
|---------|-------|-----|--|
| 7,5,3,1 | -     | -   | Reserved.  |
| 6       | -     | R/W | Enable interrupt from Timer2. 0 / 1: disable / enable.           |
| 4       | -     | R/W | Enable interrupt from comparator. 0 / 1: disable / enable.       |
| 2       | -     | R/W | Enable interrupt from Timer16 overflow. 0 / 1: disable / enable. |
| 0       | -     | R/W | Enable interrupt from PA0. 0 / 1: disable / enable.              |

### 6.5. Interrupt Request Register (*intrq*), IO address = 0x05

| Bit     | Reset | R/W | Description  |
|---------|-------|-----|--|
| 7,5,3,1 | -     | -   | Reserved.  |
| 6       | -     | R/W | Interrupt Request from Timer2, this bit is set by hardware and cleared by software.<br>0 / 1: No request / Request     |
| 4       | -     | R/W | Interrupt Request from comparator, this bit is set by hardware and cleared by software.<br>0 / 1: No request / Request |
| 2       | -     | R/W | Interrupt Request from Timer16, this bit is set by hardware and cleared by software.<br>0 / 1: No request / Request    |
| 0       | -     | R/W | Interrupt Request from pin PA0, this bit is set by hardware and cleared by software.<br>0 / 1: No request / Request    |

### 6.6. Timer 16 mode Register (*t16m*), IO address = 0x06

| Bit   | Reset | R/W | Description   |
|-------|-------|-----|---|
| 7 - 5 | 000   | R/W | Timer Clock source selection<br>000: Timer 16 is disabled<br>001: CLK (system clock)<br>010: reserved<br>011: PA4 falling edge (from external pin)<br>100: IHRC<br>101: reserved<br>110: ILRC<br>111: PA0 falling edge (from external pin)  |
| 4 - 3 | 00    | R/W | Internal clock divider.<br>00: ÷ 1<br>01: ÷ 4<br>10: ÷ 16<br>11: ÷ 64   |
| 2 - 0 | 000   | R/W | Interrupt source selection. Interrupt event happens when selected bit is changed.<br>0 : bit 8 of Timer16<br>1 : bit 9 of Timer16<br>2 : bit 10 of Timer16<br>3 : bit 11 of Timer16<br>4 : bit 12 of Timer16<br>5 : bit 13 of Timer16<br>6 : bit 14 of Timer16<br>7 : bit 15 of Timer16 |

### 6.7. External Oscillator setting Register (*eoscr*, write only), IO address = 0x0a

| Bit   | Reset | R/W | Description  |
|-------|-------|-----|--|
| 7 - 1 | -     | -   | Reserved. Please keep 0.   |
| 0     | 0     | WO  | Power-down the Bandgap and LVR hardware modules. 0 / 1: normal / power-down.<br>Note: If bandgap be disabled, there will only ILRC/T16/TM2/TM3 and I/O function can be used. |

### 6.8. Interrupt Edge Select Register (*integs*), IO address = 0x0c

| Bit   | Reset | R/W | Description  |
|-------|-------|-----|--|
| 7 - 6 | 00    | WO  | Comparator edge selection.<br>00 : both rising edge and falling edge to trigger interrupt<br>01 : rising edge to trigger interrupt<br>10 : falling edge to trigger interrupt<br>11 : reserved. |
| 5     | -     | -   | Reserved. Please keep 0.   |
| 4     | 0     | WO  | Timer16 edge selection.<br>0 : rising edge to trigger interrupt<br>1 : falling edge to trigger interrupt   |
| 3 - 2 | -     | -   | Reserved.  |
| 1 - 0 | 00    | WO  | PA0 edge selection.<br>00 : both rising edge and falling edge to trigger interrupt<br>01 : rising edge to trigger interrupt<br>10 : falling edge to trigger interrupt<br>11 : reserved.        |

### 6.9. Port A Digital Input Enable Register (*padier*), IO address = 0x0d

| Bit   | Reset | R/W | Description  |
|-------|-------|-----|--|
| 7 - 3 | 11111 | WO  | Enable PA7~PA3 digital input and wake up event. 1 / 0 : enable / disable.<br>If these bits are set to low, PA7~PA3 will be analog pins and can NOT be used to wake-up the system.  |
| 2 - 1 | -     | WO  | Reserved. (Please keep 00 for future compatibility)  |
| 0     | 1     | WO  | Enable PA0 digital input, wake up event and interrupt request. 1 / 0 : enable / disable.<br>If this bit is set to low, PA0 will be an analog pin and can NOT be used to wake-up the system, and the interrupt request from this pin will also be disabled. |

### 6.10. Port A Data Registers (*pa*), IO address = 0x10

| Bit   | Reset | R/W | Description                |
|-------|-------|-----|----------------------------|
| 7 - 0 | 8'h00 | R/W | Data registers for Port A. |

### 6.11. Port A Control Registers (*pac*), IO address = 0x11

| Bit   | Reset | R/W | Description  |
|-------|-------|-----|--|
| 7 - 0 | 8'h00 | R/W | Port A control registers. This register is used to define input mode or output mode for each corresponding pin of port A. 0 / 1: input / output. |

### 6.12. Port A Pull-High Registers (*paph*), IO address = 0x12

| Bit   | Reset | R/W | Description   |
|-------|-------|-----|---|
| 7 - 0 | 8'h00 | R/W | Port A pull-high registers. This register is used to enable the internal pull-high device on each corresponding pin of port A. 0 / 1 : disable / enable |

### 6.13. Port A Pull-Low Registers (*papl*), IO address = 0x13

| Bit   | Reset | R/W | Description   |
|-------|-------|-----|---|
| 7 - 0 | 0x00  | R/W | Port A pull-low registers. This register is used to enable the internal pull-low device on each corresponding pin of port A. 0 / 1 : disable / enable |

### 6.14. MISC Register (*misc*), IO address = 0x1b

| Bit   | Reset | R/W | Description   |
|-------|-------|-----|---|
| 7 - 6 | -     | -   | Reserved  |
| 5     | 0     | WO  | Enable fast Wake up. (Only worked in slow boot-up mode.)<br>0: Normal wake up. The wake-up time is 2048 ILRC clocks<br>1: Fast wake up. The wake-up time is 32 ILRC clocks.<br>Note:<br>The wake-up time is 32 ILRC clocks when in fast boot-up mode. |
| 4     | 0     | -   | Reserved  |
| 3     | 0     | WO  | Reserved.   |
| 2     | 0     | WO  | Disable LVR function.<br>0 / 1 : Enable / Disable   |
| 1 - 0 | 00    | WO  | Watch dog time out period<br>00: 8k ILRC clock period<br>01: 16k ILRC clock period<br>10: 64k ILRC clock period<br>11: 256k ILRC clock period   |

### 6.15. Comparator Control Register (*gpcc*), IO address = 0x1A

| Bit   | Reset | R/W | Description   |
|-------|-------|-----|---|
| 7     | 0     | R/W | Enable comparator.<br>0 / 1 : disable / enable<br>When this bit is set to enable, please also set the corresponding analog input pins to be digital disable to prevent IO leakage.  |
| 6     | -     | RO  | Comparator result of comparator.<br>0: plus input < minus input<br>1: plus input > minus input  |
| 5     | 0     | R/W | Select whether the comparator result output will be sampled by TM2_CLK?<br>0: result output NOT sampled by TM2_CLK<br>1: result output sampled by TM2_CLK   |
| 4     | 0     | R/W | Inverse the polarity of result output of comparator.<br>0: polarity is NOT inversed.<br>1: polarity is inversed.  |
| 3 - 1 | 000   | R/W | Selection the minus input (-) of comparator.<br>000 : PA3<br>001 : PA4<br>010 : Internal 1.20 volt bandgap reference voltage (not suitable for the comparator wake-up function)<br>011 : $V_{internal R}$<br>100 : PA6 (not for 5S-I-S01/2(B))<br>101 : PA7 (not for 5S-I-S01/2(B))<br>11X : reserved |
| 0     | 0     | R/W | Selection the plus input (+) of comparator.<br>0 : $V_{internal R}$<br>1 : PA4  |



### 6.16. Comparator Selection Register (*gpcs*), IO address = 0x1E

| Bit   | Reset | R/W | Description   |
|-------|-------|-----|---|
| 7     | 0     | WO  | Comparator output enable (to PA0).<br>0 / 1 : disable / enable<br>(Please avoid this situation: GPCS will affect the PA3 output function when selecting output to PA0 output in ICE.) |
| 6     | 0     | WO  | Wakeup by comparator enable. (The comparator wake-up effectively when gpcc.6 electrical level changed.)<br>0 / 1 : disable / enable   |
| 5     | 0     | WO  | Selection of high range of comparator.  |
| 4     | 0     | WO  | Selection of low range of comparator.   |
| 3 - 0 | 0000  | WO  | Selection the voltage level of comparator.<br>0000 (lowest) ~ 1111 (highest)  |

### 6.17. Timer2 Control Register (*tm2c*), IO address = 0x1C

| Bit   | Reset | R/W | Description  |
|-------|-------|-----|--|
| 7 - 4 | 0000  | R/W | Timer2 clock selection.<br>0000 : disable<br>0001 : CLK<br>0010 : IHRC<br>0011 : reserved<br>0100 : ILRC<br>0101 : comparator output<br>1000 : PA0 (rising edge)<br>1001 : ~PA0 (falling edge)<br>1100 : PA4 (rising edge)<br>1101 : ~PA4 (falling edge)<br>Others: reserved<br><b>Notice:</b> In ICE mode and IHRC is selected for Timer2 clock, the clock sent to Timer2 does NOT be stopped, Timer2 will keep counting when ICE is in halt state. |
| 3 - 2 | 00    | R/W | Timer2 output selection.<br>00 : disable<br>01 : reserved<br>10 : PA3<br>11 : PA4 (not for 5S-I-S01/2(B))  |
| 1     | 0     | R/W | Timer2 mode selection.<br>0 / 1 : period mode / PWM mode   |
| 0     | 0     | R/W | Enable to inverse the polarity of Timer2 output.<br>0 / 1: disable / enable  |

### 6.18. Timer2 Counter Register (*tm2ct*), IO address = 0x1D

| Bit   | Reset | R/W | Description                           |
|-------|-------|-----|---------------------------------------|
| 7 - 0 | 0x00  | R/W | Bit [7:0] of Timer2 counter register. |

### 6.19. Timer2 Bound Register (*tm2b*), IO address = 0x09

| Bit   | Reset | R/W | Description            |
|-------|-------|-----|------------------------|
| 7 - 0 | 0x00  | WO  | Timer2 bound register. |

### 6.20. Timer2 Scalar Register (*tm2s*), IO address = 0x17

| Bit   | Reset | R/W | Description  |
|-------|-------|-----|--|
| 7     | 0     | WO  | PWM resolution selection.<br>0 : 8-bit<br>1 : 6-bit                        |
| 6 - 5 | 00    | WO  | Timer2 clock pre-scalar.<br>00 : ÷ 1<br>01 : ÷ 4<br>10 : ÷ 16<br>11 : ÷ 64 |
| 4 - 0 | 00000 | WO  | Timer2 clock scalar.   |

### 7. Instructions

| Symbol       | Description   |
|--------------|---|
| <b>ACC</b>   | Accumulator ( Abbreviation of accumulator )   |
| <b>a</b>     | Accumulator ( Symbol of accumulator in program )  |
| <b>sp</b>    | Stack pointer   |
| <b>flag</b>  | ACC status flag register  |
| <b>I</b>     | Immediate data  |
| <b>&amp;</b> | Logical AND   |
| <b> </b>     | Logical OR  |
| <b>←</b>     | Movement  |
| <b>^</b>     | Exclusive logic OR  |
| <b>+</b>     | Add   |
| <b>−</b>     | Subtraction   |
| <b>~</b>     | NOT (logical complement, 1's complement)  |
| <b>¯</b>     | NEG (2's complement)  |
| <b>OV</b>    | Overflow (The operational result is out of range in signed 2's complement number system)                                      |
| <b>Z</b>     | Zero (If the result of ALU operation is zero, this bit is set to 1)   |
| <b>C</b>     | Carry (The operational result is to have carry out for addition or to borrow carry for subtraction in unsigned number system) |
| <b>AC</b>    | Auxiliary Carry (If there is a carry out from low nibble after the result of ALU operation, this bit is set to 1)             |
| <b>word</b>  | Only addressed in 0~0x1F (0~31) is allowed  |
| <b>M.n</b>   | Only addressed in 0~0xF (0~15) is allowed   |
| <b>IO.n</b>  | The bit of register   |

### 7.1. Data Transfer Instructions

|                   |   |
|-------------------|---|
| <i>mov</i> a, I   | <p>Move immediate data into ACC.<br/> Example: <i>mov</i> a, 0x0f;<br/> Result: a ← 0fh;<br/> Affected flags: [N] Z [N] C [N] AC [N] OV</p>   |
| <i>mov</i> M, a   | <p>Move data from ACC into memory<br/> Example: <i>mov</i> MEM, a;<br/> Result: MEM ← a<br/> Affected flags: [N] Z [N] C [N] AC [N] OV</p>  |
| <i>mov</i> a, M   | <p>Move data from memory into ACC<br/> Example: <i>mov</i> a, MEM ;<br/> Result: a ← MEM; Flag Z is set when MEM is zero.<br/> Affected flags: [Y] Z [N] C [N] AC [N] OV</p>  |
| <i>mov</i> a, IO  | <p>Move data from IO into ACC<br/> Example: <i>mov</i> a, pa ;<br/> Result: a ← pa; Flag Z is set when pa is zero.<br/> Affected flags: [Y] Z [N] C [N] AC [N] OV</p>   |
| <i>mov</i> IO, a  | <p>Move data from ACC into IO<br/> Example: <i>mov</i> pa, a;<br/> Result: pa ← a<br/> Affected flags: [N] Z [N] C [N] AC [N] OV</p>  |
| <i>ldt16</i> word | <p>Move 16-bit counting values in Timer16 to memory in word.<br/> Example: <i>ldt16</i> word;<br/> Result: word ← 16-bit timer<br/> Affected flags: [N] Z [N] C [N] AC [N] OV</p> <p>Application Example:</p> <pre> ----- word    T16val ;           // declare a RAM word ... clear   lb@ T16val ;       // clear T16val (LSB) clear   hb@ T16val ;       // clear T16val (MSB) stt16   T16val ;           // initial T16 with 0 ... set1    t16m.5 ;           // enable Timer16 ... set0    t16m.5 ;           // disable Timer 16 ldt16   T16val ;           // save the T16 counting value to T16val .... ----- </pre> |

|                             |  |
|-----------------------------|--|
| <p><i>stt16</i> word</p>    | <p>Store 16-bit data from memory in word to Timer16.<br/> Example: <i>stt16</i> word;<br/> Result: 16-bit timer ← word<br/> Affected flags: [N] Z [N] C [N] AC [N] OV</p> <p>Application Example:</p> <hr/> <pre> word    T16val ;           // declare a RAM word ... mov     a, 0x34 ; mov     lb@ T16val , a ;    // move 0x34 to T16val (LSB) mov     a, 0x12 ; mov     hb@ T16val , a ;    // move 0x12 to T16val (MSB) stt16   T16val ;           // initial T16 with 0x1234 ... </pre> <hr/>  |
| <p><i>idxm</i> a, index</p> | <p>Move data from specified memory to ACC by indirect method. It needs 2T to execute this instruction.<br/> Example: <i>idxm</i> a, index;<br/> Result: a ← [index], where index is declared by word.<br/> Affected flags: [N] Z [N] C [N] AC [N] OV</p> <p>Application Example:</p> <hr/> <pre> word    RAMIndex ;         // declare a RAM pointer ... mov     a, 0x5B ;           // assign pointer to an address (LSB) mov     lb@RAMIndex, a ;    // save pointer to RAM (LSB) mov     a, 0x00 ;           // assign 0x00 to an address (MSB), should be 0 mov     hb@RAMIndex, a ;    // save pointer to RAM (MSB) ... idxm    a, RAMIndex ;       // move memory data in address 0x5B to ACC </pre> <hr/> |

|                      |  |
|----------------------|--|
| <i>idxm</i> index, a | <p>Move data from ACC to specified memory by indirect method. It needs 2T to execute this instruction.</p> <p>Example: <i>idxm</i> index, a;</p> <p>Result: [index] ← a; where index is declared by word.</p> <p>Affected flags: [N] Z [N] C [N] AC [N] OV</p> <p>Application Example:</p> <hr/> <pre> word    RAMIndex ;           // declare a RAM pointer ... mov     a, 0x5B ;           // assign pointer to an address (LSB) mov     lb@RAMIndex, a ;    // save pointer to RAM (LSB) mov     a, 0x00 ;           // assign 0x00 to an address (MSB), should be 0 mov     hb@RAMIndex, a ;    // save pointer to RAM (MSB) ... mov     a, 0xA5 ; idxm    RAMIndex, a ;       // move 0xA5 to memory in address 0x5B           </pre> <hr/> |
| <i>xch</i> M         | <p>Exchange data between ACC and memory</p> <p>Example: <i>xch</i> MEM ;</p> <p>Result: MEM ← a , a ← MEM</p> <p>Affected flags: [N] Z [N] C [N] AC [N] OV</p>   |
| <i>pushaf</i>        | <p>Move the ACC and flag register to memory that address specified in the stack pointer.</p> <p>Example: <i>pushaf</i>;</p> <p>Result: [sp] ← {flag, ACC};<br/>sp ← sp + 2 ;</p> <p>Affected flags: [N] Z [N] C [N] AC [N] OV</p> <p>Application Example:</p> <hr/> <pre> .romadr 0x10 ;           // ISR entry address pushaf ;                 // put ACC and flag into stack memory ...                       // ISR program ...                       // ISR program popaf ;                   // restore ACC and flag from stack memory reti ;           </pre> <hr/>   |
| <i>popaf</i>         | <p>Restore ACC and flag from the memory which address is specified in the stack pointer.</p> <p>Example: <i>popaf</i>;</p> <p>Result: sp ← sp - 2 ;<br/>{Flag, ACC} ← [sp] ;</p> <p>Affected flags: [Y] Z [Y] C [Y] AC [Y] OV</p>  |

### 7.2. Arithmetic Operation Instructions

|                  |  |
|------------------|--|
| <i>add</i> a, l  | Add immediate data with ACC, then put result into ACC<br>Example: <i>add</i> a, 0x0f ;<br>Result: $a \leftarrow a + 0fh$<br>Affected flags: [Y] Z [Y] C [Y] AC [Y] OV  |
| <i>add</i> a, M  | Add data in memory with ACC, then put result into ACC<br>Example: <i>add</i> a, MEM ;<br>Result: $a \leftarrow a + MEM$<br>Affected flags: [Y] Z [Y] C [Y] AC [Y] OV   |
| <i>add</i> M, a  | Add data in memory with ACC, then put result into memory<br>Example: <i>add</i> MEM, a ;<br>Result: $MEM \leftarrow a + MEM$<br>Affected flags: [Y] Z [Y] C [Y] AC [Y] OV  |
| <i>addc</i> a, M | Add data in memory with ACC and carry bit, then put result into ACC<br>Example: <i>addc</i> a, MEM ;<br>Result: $a \leftarrow a + MEM + C$<br>Affected flags: [Y] Z [Y] C [Y] AC [Y] OV                                    |
| <i>addc</i> M, a | Add data in memory with ACC and carry bit, then put result into memory<br>Example: <i>addc</i> MEM, a ;<br>Result: $MEM \leftarrow a + MEM + C$<br>Affected flags: [Y] Z [Y] C [Y] AC [Y] OV                               |
| <i>addc</i> a    | Add carry with ACC, then put result into ACC<br>Example: <i>addc</i> a ;<br>Result: $a \leftarrow a + C$<br>Affected flags: [Y] Z [Y] C [Y] AC [Y] OV  |
| <i>addc</i> M    | Add carry with memory, then put result into memory<br>Example: <i>addc</i> MEM ;<br>Result: $MEM \leftarrow MEM + C$<br>Affected flags: [Y] Z [Y] C [Y] AC [Y] OV  |
| <i>sub</i> a, l  | Subtraction immediate data from ACC, then put result into ACC.<br>Example: <i>sub</i> a, 0x0f ;<br>Result: $a \leftarrow a - 0fh ( a + [2's \text{ complement of } 0fh] )$<br>Affected flags: [Y] Z [Y] C [Y] AC [Y] OV    |
| <i>sub</i> a, M  | Subtraction data in memory from ACC, then put result into ACC<br>Example: <i>sub</i> a, MEM ;<br>Result: $a \leftarrow a - MEM ( a + [2's \text{ complement of } M] )$<br>Affected flags: [Y] Z [Y] C [Y] AC [Y] OV        |
| <i>sub</i> M, a  | Subtraction data in ACC from memory, then put result into memory<br>Example: <i>sub</i> MEM, a ;<br>Result: $MEM \leftarrow MEM - a ( MEM + [2's \text{ complement of } a] )$<br>Affected flags: [Y] Z [Y] C [Y] AC [Y] OV |
| <i>subc</i> a, M | Subtraction data in memory and carry from ACC, then put result into ACC<br>Example: <i>subc</i> a, MEM ;<br>Result: $a \leftarrow a - MEM - C$<br>Affected flags: [Y] Z [Y] C [Y] AC [Y] OV                                |

|                  |  |
|------------------|--|
| <i>subc</i> M, a | Subtraction ACC and carry bit from memory, then put result into memory<br>Example: <i>subc</i> MEM, a ;<br>Result: $MEM \leftarrow MEM - a - C$<br>Affected flags: [Y] Z [Y] C [Y] AC [Y] OV |
| <i>subc</i> a    | Subtraction carry from ACC, then put result into ACC<br>Example: <i>subc</i> a ;<br>Result: $a \leftarrow a - C$<br>Affected flags: [Y] Z [Y] C [Y] AC [Y] OV                                |
| <i>subc</i> M    | Subtraction carry from the content of memory, then put result into memory<br>Example: <i>subc</i> MEM ;<br>Result: $MEM \leftarrow MEM - C$<br>Affected flags: [Y] Z [Y] C [Y] AC [Y] OV     |
| <i>inc</i> M     | Increment the content of memory<br>Example: <i>inc</i> MEM ;<br>Result: $MEM \leftarrow MEM + 1$<br>Affected flags: [Y] Z [Y] C [Y] AC [Y] OV  |
| <i>dec</i> M     | Decrement the content of memory<br>Example: <i>dec</i> MEM ;<br>Result: $MEM \leftarrow MEM - 1$<br>Affected flags: [Y] Z [Y] C [Y] AC [Y] OV  |
| <i>clear</i> M   | Clear the content of memory<br>Example: <i>clear</i> MEM ;<br>Result: $MEM \leftarrow 0$<br>Affected flags: [N] Z [N] C [N] AC [N] OV  |

### 7.3. Shift Operation Instructions

|              |  |
|--------------|--|
| <i>sr</i> a  | Shift right of ACC, shift 0 to bit 7<br>Example: <i>sr</i> a ;<br>Result: $a(0, b7, b6, b5, b4, b3, b2, b1) \leftarrow a(b7, b6, b5, b4, b3, b2, b1, b0)$ , $C \leftarrow a(b0)$<br>Affected flags: [N] Z [Y] C [N] AC [N] OV                        |
| <i>src</i> a | Shift right of ACC with carry bit 7 to flag<br>Example: <i>src</i> a ;<br>Result: $a(c, b7, b6, b5, b4, b3, b2, b1) \leftarrow a(b7, b6, b5, b4, b3, b2, b1, b0)$ , $C \leftarrow a(b0)$<br>Affected flags: [N] Z [Y] C [N] AC [N] OV                |
| <i>sr</i> M  | Shift right the content of memory, shift 0 to bit 7<br>Example: <i>sr</i> MEM ;<br>Result: $MEM(0, b7, b6, b5, b4, b3, b2, b1) \leftarrow MEM(b7, b6, b5, b4, b3, b2, b1, b0)$ , $C \leftarrow MEM(b0)$<br>Affected flags: [N] Z [Y] C [N] AC [N] OV |
| <i>src</i> M | Shift right of memory with carry bit 7 to flag<br>Example: <i>src</i> MEM ;<br>Result: $MEM(c, b7, b6, b5, b4, b3, b2, b1) \leftarrow MEM(b7, b6, b5, b4, b3, b2, b1, b0)$ , $C \leftarrow MEM(b0)$<br>Affected flags: [N] Z [Y] C [N] AC [N] OV     |
| <i>sl</i> a  | Shift left of ACC shift 0 to bit 0<br>Example: <i>sl</i> a ;<br>Result: $a(b6, b5, b4, b3, b2, b1, b0, 0) \leftarrow a(b7, b6, b5, b4, b3, b2, b1, b0)$ , $C \leftarrow a(b7)$<br>Affected flags: [N] Z [Y] C [N] AC [N] OV                          |
| <i>slc</i> a | Shift left of ACC with carry bit 0 to flag   |



|                     |  |
|---------------------|--|
|                     | <p>Example: <code>s/c a ;</code><br/>           Result: <math>a (b6,b5,b4,b3,b2,b1,b0,c) \leftarrow a (b7,b6,b5,b4,b3,b2,b1,b0), C \leftarrow a(b7)</math><br/>           Affected flags: <math>\{N\} Z \{Y\} C \{N\} AC \{N\} OV</math></p>   |
| <code>s/ M</code>   | <p>Shift left of memory, shift 0 to bit 0<br/>           Example: <code>s/ MEM ;</code><br/>           Result: <math>MEM (b6,b5,b4,b3,b2,b1,b0,0) \leftarrow MEM (b7,b6,b5,b4,b3,b2,b1,b0), C \leftarrow MEM(b7)</math><br/>           Affected flags: <math>\{N\} Z \{Y\} C \{N\} AC \{N\} OV</math></p>          |
| <code>s/c M</code>  | <p>Shift left of memory with carry bit 0 to flag<br/>           Example: <code>s/c MEM ;</code><br/>           Result: <math>MEM (b6,b5,b4,b3,b2,b1,b0,C) \leftarrow MEM (b7,b6,b5,b4,b3,b2,b1,b0), C \leftarrow MEM (b7)</math><br/>           Affected flags: <math>\{N\} Z \{Y\} C \{N\} AC \{N\} OV</math></p> |
| <code>swap a</code> | <p>Swap the high nibble and low nibble of ACC<br/>           Example: <code>swap a ;</code><br/>           Result: <math>a (b3,b2,b1,b0,b7,b6,b5,b4) \leftarrow a (b7,b6,b5,b4,b3,b2,b1,b0)</math><br/>           Affected flags: <math>\{N\} Z \{N\} C \{N\} AC \{N\} OV</math></p>                               |

### 7.4. Logic Operation Instructions

|                        |   |
|------------------------|---|
| <code>and a, l</code>  | <p>Perform logic AND on ACC and immediate data, then put result into ACC<br/>           Example: <code>and a, 0x0f ;</code><br/>           Result: <math>a \leftarrow a \&amp; 0fh</math><br/>           Affected flags: <math>\{Y\} Z \{N\} C \{N\} AC \{N\} OV</math></p> |
| <code>and a, M</code>  | <p>Perform logic AND on ACC and memory, then put result into ACC<br/>           Example: <code>and a, RAM10 ;</code><br/>           Result: <math>a \leftarrow a \&amp; RAM10</math><br/>           Affected flags: <math>\{Y\} Z \{N\} C \{N\} AC \{N\} OV</math></p>      |
| <code>and M, a</code>  | <p>Perform logic AND on ACC and memory, then put result into memory<br/>           Example: <code>and MEM, a ;</code><br/>           Result: <math>MEM \leftarrow a \&amp; MEM</math><br/>           Affected flags: <math>\{Y\} Z \{N\} C \{N\} AC \{N\} OV</math></p>     |
| <code>or a, l</code>   | <p>Perform logic OR on ACC and immediate data, then put result into ACC<br/>           Example: <code>or a, 0x0f ;</code><br/>           Result: <math>a \leftarrow a   0fh</math><br/>           Affected flags: <math>\{Y\} Z \{N\} C \{N\} AC \{N\} OV</math></p>        |
| <code>or a, M</code>   | <p>Perform logic OR on ACC and memory, then put result into ACC<br/>           Example: <code>or a, MEM ;</code><br/>           Result: <math>a \leftarrow a   MEM</math><br/>           Affected flags: <math>\{Y\} Z \{N\} C \{N\} AC \{N\} OV</math></p>                 |
| <code>or M, a</code>   | <p>Perform logic OR on ACC and memory, then put result into memory<br/>           Example: <code>or MEM, a ;</code><br/>           Result: <math>MEM \leftarrow a   MEM</math><br/>           Affected flags: <math>\{Y\} Z \{N\} C \{N\} AC \{N\} OV</math></p>            |
| <code>xor a, l</code>  | <p>Perform logic XOR on ACC and immediate data, then put result into ACC<br/>           Example: <code>xor a, 0x0f ;</code><br/>           Result: <math>a \leftarrow a \wedge 0fh</math><br/>           Affected flags: <math>\{Y\} Z \{N\} C \{N\} AC \{N\} OV</math></p> |
| <code>xor IO, a</code> | <p>Perform logic XOR on ACC and IO register, then put result into IO register</p>   |

|                       |   |
|-----------------------|---|
|                       | <p>Example: <code>xor pa, a ;</code><br/> Result: <math>pa \leftarrow a \wedge pa</math> ; // pa is the data register of port A<br/> Affected flags: [N] Z [N] C [N] AC [N] OV</p>  |
| <code>xor a, M</code> | <p>Perform logic XOR on ACC and memory, then put result into ACC<br/> Example: <code>xor a, MEM ;</code><br/> Result: <math>a \leftarrow a \wedge RAM10</math><br/> Affected flags: [Y] Z [N] C [N] AC [N] OV</p>   |
| <code>xor M, a</code> | <p>Perform logic XOR on ACC and memory, then put result into memory<br/> Example: <code>xor MEM, a ;</code><br/> Result: <math>MEM \leftarrow a \wedge MEM</math><br/> Affected flags: [Y] Z [N] C [N] AC [N] OV</p>  |
| <code>not a</code>    | <p>Perform 1's complement (logical complement) of ACC<br/> Example: <code>not a ;</code><br/> Result: <math>a \leftarrow \sim a</math><br/> Affected flags: [Y] Z [N] C [N] AC [N] OV</p> <p>Application Example:</p> <hr/> <pre> mov    a, 0x38 ; // ACC=0X38 not    a ; // ACC=0XC7 </pre> <hr/>                                |
| <code>not M</code>    | <p>Perform 1's complement (logical complement) of memory<br/> Example: <code>not MEM ;</code><br/> Result: <math>MEM \leftarrow \sim MEM</math><br/> Affected flags: [Y] Z [N] C [N] AC [N] OV</p> <p>Application Example:</p> <hr/> <pre> mov    a, 0x38 ; mov    mem, a ; // mem = 0x38 not    mem ; // mem = 0xC7 </pre> <hr/> |
| <code>neg a</code>    | <p>Perform 2's complement of ACC<br/> Example: <code>neg a ;</code><br/> Result: <math>a \leftarrow \bar{a}</math><br/> Affected flags: [Y] Z [N] C [N] AC [N] OV</p> <p>Application Example:</p> <hr/> <pre> mov    a, 0x38 ; // ACC=0X38 neg    a ; // ACC=0XC8 </pre> <hr/>  |
| <code>neg M</code>    | <p>Perform 2's complement of memory</p>   |

|  |  |
|--|--|
|  | <p>Example: <code>neg MEM;</code><br/> Result: <math>MEM \leftarrow \bar{MEM}</math><br/> Affected flags: [Y] Z [N] C [N] AC [N] OV</p> <p>Application Example:</p> <hr/> <pre> mov    a, 0x38 ; mov    mem, a ;    // mem = 0x38 not    mem ;      // mem = 0xC8 </pre> <hr/> |
|--|--|

### 7.5. Bit Operation Instructions

|                        |  |
|------------------------|--|
| <code>set0 IO.n</code> | <p>Set bit n of IO port to low<br/> Example: <code>set0 pa.5 ;</code><br/> Result: set bit 5 of port A to low<br/> Affected flags: [N] Z [N] C [N] AC [N] OV</p>   |
| <code>set1 IO.n</code> | <p>Set bit n of IO port to high<br/> Example: <code>set1 pa.5 ;</code><br/> Result: set bit 5 of port A to high<br/> Affected flags: [N] Z [N] C [N] AC [N] OV</p> |
| <code>set0 M.n</code>  | <p>Set bit n of memory to low<br/> Example: <code>set0 MEM.5 ;</code><br/> Result: set bit 5 of MEM to low<br/> Affected flags: [N] Z [N] C [N] AC [N] OV</p>      |
| <code>set1 M.n</code>  | <p>Set bit n of memory to high<br/> Example: <code>set1 MEM.5 ;</code><br/> Result: set bit 5 of MEM to high<br/> Affected flags: [N] Z [N] C [N] AC [N] OV</p>    |

### 7.6. Conditional Operation Instructions

|                         |  |
|-------------------------|--|
| <code>ceqsn a, l</code> | <p>Compare ACC with immediate data and skip next instruction if both are equal.<br/> Flag will be changed like as (<math>a \leftarrow a - l</math>)<br/> Example: <code>ceqsn a, 0x55 ;</code><br/> <code>inc MEM ;</code><br/> <code>goto error ;</code><br/> Result: If <math>a=0x55</math>, then “goto error”; otherwise, “inc MEM”.<br/> Affected flags: [Y] Z [Y] C [Y] AC [Y] OV</p> |
| <code>ceqsn a, M</code> | <p>Compare ACC with memory and skip next instruction if both are equal.<br/> Flag will be changed like as (<math>a \leftarrow a - M</math>)<br/> Example: <code>ceqsn a, MEM ;</code><br/> Result: If <math>a=MEM</math>, skip next instruction<br/> Affected flags: [Y] Z [Y] C [Y] AC [Y] OV</p>   |
| <code>t0sn IO.n</code>  | <p>Check IO bit and skip next instruction if it's low<br/> Example: <code>t0sn pa.5 ;</code><br/> Result: If bit 5 of port A is low, skip next instruction<br/> Affected flags: [N] Z [N] C [N] AC [N] OV</p>  |
| <code>t1sn IO.n</code>  | <p>Check IO bit and skip next instruction if it's high</p>   |

|                 |  |
|-----------------|--|
|                 | <p>Example: <i>t1sn pa.5</i> ;</p> <p>Result: If bit 5 of port A is high, skip next instruction</p> <p>Affected flags: [N] Z [N] C [N] AC [N] OV</p>   |
| <i>t0sn M.n</i> | <p>Check memory bit and skip next instruction if it's low</p> <p>Example: <i>t0sn MEM.5</i> ;</p> <p>Result: If bit 5 of MEM is low, then skip next instruction</p> <p>Affected flags: [N] Z [N] C [N] AC [N] OV</p>                                     |
| <i>t1sn M.n</i> | <p>Check memory bit and skip next instruction if it's high</p> <p>EX: <i>t1sn MEM.5</i> ;</p> <p>Result: If bit 5 of MEM is high, then skip next instruction</p> <p>Affected flags: [N] Z [N] C [N] AC [N] OV</p>  |
| <i>izsn a</i>   | <p>Increment ACC and skip next instruction if ACC is zero</p> <p>Example: <i>izsn a</i> ;</p> <p>Result: <math>a \leftarrow a + 1</math>, skip next instruction if <math>a = 0</math></p> <p>Affected flags: [Y] Z [Y] C [Y] AC [Y] OV</p>               |
| <i>dzsn a</i>   | <p>Decrement ACC and skip next instruction if ACC is zero</p> <p>Example: <i>dzsn a</i> ;</p> <p>Result: <math>A \leftarrow A - 1</math>, skip next instruction if <math>a = 0</math></p> <p>Affected flags: [Y] Z [Y] C [Y] AC [Y] OV</p>               |
| <i>izsn M</i>   | <p>Increment memory and skip next instruction if memory is zero</p> <p>Example: <i>izsn MEM</i> ;</p> <p>Result: <math>MEM \leftarrow MEM + 1</math>, skip next instruction if <math>MEM = 0</math></p> <p>Affected flags: [Y] Z [Y] C [Y] AC [Y] OV</p> |
| <i>dzsn M</i>   | <p>Decrement memory and skip next instruction if memory is zero</p> <p>Example: <i>dzsn MEM</i> ;</p> <p>Result: <math>MEM \leftarrow MEM - 1</math>, skip next instruction if <math>MEM = 0</math></p> <p>Affected flags: [Y] Z [Y] C [Y] AC [Y] OV</p> |

### 7.7. System control Instructions

|                   |  |
|-------------------|--|
| <i>call label</i> | <p>Function call, address can be full range address space</p> <p>Example: <i>call function1</i> ;</p> <p>Result: <math>[sp] \leftarrow pc + 1</math><br/> <math>pc \leftarrow function1</math><br/> <math>sp \leftarrow sp + 2</math></p> <p>Affected flags: [N] Z [N] C [N] AC [N] OV</p> |
| <i>goto label</i> | <p>Go to specific address which can be full range address space</p> <p>Example: <i>goto error</i> ;</p> <p>Result: Go to error and execute program.</p> <p>Affected flags: [N] Z [N] C [N] AC [N] OV</p>   |
| <i>ret I</i>      | <p>Place immediate data to ACC, then return</p> <p>Example: <i>ret 0x55</i> ;</p> <p>Result: <math>A \leftarrow 55h</math><br/> <math>ret</math> ;</p> <p>Affected flags: [N] Z [N] C [N] AC [N] OV</p>  |
| <i>ret</i>        | <p>Return to program which had function call</p>   |

|                |   |
|----------------|---|
|                | <p>Example: <i>ret</i>;</p> <p>Result: <math>sp \leftarrow sp - 2</math><br/> <math>pc \leftarrow [sp]</math></p> <p>Affected flags: [N] Z [N] C [N] AC [N] OV</p>  |
| <i>reti</i>    | <p>Return to program from interrupt service routine. After this command is executed, global interrupt is enabled automatically.</p> <p>Example: <i>reti</i>;</p> <p>Affected flags: [N] Z [N] C [N] AC [N] OV</p>   |
| <i>nop</i>     | <p>No operation</p> <p>Example: <i>nop</i>;</p> <p>Result: nothing changed</p> <p>Affected flags: [N] Z [N] C [N] AC [N] OV</p>   |
| <i>pcadd a</i> | <p>Next program counter is current program counter plus ACC.</p> <p>Example: <i>pcadd a</i>;</p> <p>Result: <math>pc \leftarrow pc + a</math></p> <p>Affected flags: [N] Z [N] C [N] AC [N] OV</p> <p>Application Example:</p> <pre> ----- ... mov    a, 0x02 ; pcadd  a ;           // PC &lt;- PC+2 goto   err1 ; goto   correct ;    // jump here goto   err2 ; goto   err3 ; ... correct:           // jump here ... ----- </pre> |
| <i>engint</i>  | <p>Enable global interrupt enable</p> <p>Example: <i>engint</i>;</p> <p>Result: Interrupt request can be sent to FPP0</p> <p>Affected flags: [N] Z [N] C [N] AC [N] OV</p>  |
| <i>disgint</i> | <p>Disable global interrupt enable</p> <p>Example: <i>disgint</i>;</p> <p>Result: Interrupt request is blocked from FPP0</p> <p>Affected flags: [N] Z [N] C [N] AC [N] OV</p>   |
| <i>stopsys</i> | <p>System halt.</p> <p>Example: <i>stopsys</i>;</p> <p>Result: Stop the system clocks and halt the system</p> <p>Affected flags: [N] Z [N] C [N] AC [N] OV</p>  |
| <i>stopexe</i> | <p>CPU halt. The oscillator module is still active to output clock, however, system clock is disabled to save power.</p> <p>Example: <i>stopexe</i>;</p> <p>Result: Stop the system clocks and keep oscillator modules active.</p> <p>Affected flags: [N] Z [N] C [N] AC [N] OV</p>   |

|                |   |
|----------------|---|
| <i>reset</i>   | Reset the whole chip, its operation will be same as hardware reset.<br>Example: <code>reset;</code><br>Result: Reset the whole chip.<br>Affected flags: [N] Z [N] C [N] AC [N] OV |
| <i>wdreset</i> | Reset Watchdog timer.<br>Example: <code>wdreset;</code><br>Result: Reset Watchdog timer.<br>Affected flags: [N] Z [N] C [N] AC [N] OV   |

### 7.8. Summary of Instructions Execution Cycle

|    |                            |  |
|----|----------------------------|--|
| 2T |                            | <i>goto, call, idxm, pcadd, ret, reti</i>    |
| 2T | Condition is fulfilled     | <i>ceqsn, cneqsn, t0sn, t1sn, dzsn, izsn</i> |
| 1T | Condition is not fulfilled |  |
| 1T |                            | Others                                       |

### 7.9. Summary of affected flags by Instructions

| Instruction       | Z | C | AC | OV | Instruction          | Z | C | AC | OV | Instruction          | Z | C | AC | OV |
|-------------------|---|---|----|----|----------------------|---|---|----|----|----------------------|---|---|----|----|
| <i>mov</i> a, l   | - | - | -  | -  | <i>mov</i> M, a      | - | - | -  | -  | <i>mov</i> a, M      | Y | - | -  | -  |
| <i>mov</i> a, IO  | Y | - | -  | -  | <i>mov</i> IO, a     | - | - | -  | -  | <i>ldt16</i> word    | - | - | -  | -  |
| <i>stt16</i> word | - | - | -  | -  | <i>idxm</i> a, index | - | - | -  | -  | <i>idxm</i> index, a | - | - | -  | -  |
| <i>xch</i> M      | - | - | -  | -  | <i>pushaf</i>        | - | - | -  | -  | <i>popaf</i>         | Y | Y | Y  | Y  |
| <i>add</i> a, l   | Y | Y | Y  | Y  | <i>add</i> a, M      | Y | Y | Y  | Y  | <i>add</i> M, a      | Y | Y | Y  | Y  |
| <i>addc</i> a, M  | Y | Y | Y  | Y  | <i>addc</i> M, a     | Y | Y | Y  | Y  | <i>addc</i> a        | Y | Y | Y  | Y  |
| <i>addc</i> M     | Y | Y | Y  | Y  | <i>sub</i> a, l      | Y | Y | Y  | Y  | <i>sub</i> a, M      | Y | Y | Y  | Y  |
| <i>sub</i> M, a   | Y | Y | Y  | Y  | <i>subc</i> a, M     | Y | Y | Y  | Y  | <i>subc</i> M, a     | Y | Y | Y  | Y  |
| <i>subc</i> a     | Y | Y | Y  | Y  | <i>subc</i> M        | Y | Y | Y  | Y  | <i>inc</i> M         | Y | Y | Y  | Y  |
| <i>dec</i> M      | Y | Y | Y  | Y  | <i>clear</i> M       | - | - | -  | -  | <i>sr</i> a          | - | Y | -  | -  |
| <i>src</i> a      | - | Y | -  | -  | <i>sr</i> M          | - | Y | -  | -  | <i>src</i> M         | - | Y | -  | -  |
| <i>sl</i> a       | - | Y | -  | -  | <i>slc</i> a         | - | Y | -  | -  | <i>sl</i> M          | - | Y | -  | -  |
| <i>slc</i> M      | - | Y | -  | -  | <i>swap</i> a        | - | - | -  | -  | <i>and</i> a, l      | Y | - | -  | -  |
| <i>and</i> a, M   | Y | - | -  | -  | <i>and</i> M, a      | Y | - | -  | -  | <i>or</i> a, l       | Y | - | -  | -  |
| <i>or</i> a, M    | Y | - | -  | -  | <i>or</i> M, a       | Y | - | -  | -  | <i>xor</i> a, l      | Y | - | -  | -  |
| <i>xor</i> IO, a  | - | - | -  | -  | <i>xor</i> a, M      | Y | - | -  | -  | <i>xor</i> M, a      | Y | - | -  | -  |
| <i>not</i> a      | Y | - | -  | -  | <i>not</i> M         | Y | - | -  | -  | <i>neg</i> a         | Y | - | -  | -  |
| <i>neg</i> M      | Y | - | -  | -  | <i>set0</i> IO.n     | - | - | -  | -  | <i>set1</i> IO.n     | - | - | -  | -  |
| <i>set0</i> M.n   | - | - | -  | -  | <i>set1</i> M.n      | - | - | -  | -  | <i>ceqsn</i> a, l    | Y | Y | Y  | Y  |
| <i>ceqsn</i> a, M | Y | Y | Y  | Y  | <i>t0sn</i> IO.n     | - | - | -  | -  | <i>t1sn</i> IO.n     | - | - | -  | -  |
| <i>t0sn</i> M.n   | - | - | -  | -  | <i>t1sn</i> M.n      | - | - | -  | -  | <i>izsn</i> a        | Y | Y | Y  | Y  |
| <i>dzsn</i> a     | Y | Y | Y  | Y  | <i>izsn</i> M        | Y | Y | Y  | Y  | <i>dzsn</i> M        | Y | Y | Y  | Y  |
| <i>call</i> label | - | - | -  | -  | <i>goto</i> label    | - | - | -  | -  | <i>ret</i> l         | - | - | -  | -  |
| <i>ret</i>        | - | - | -  | -  | <i>reti</i>          | - | - | -  | -  | <i>nop</i>           | - | - | -  | -  |
| <i>pcadd</i> a    | - | - | -  | -  | <i>engint</i>        | - | - | -  | -  | <i>disgint</i>       | - | - | -  | -  |
| <i>stopsys</i>    | - | - | -  | -  | <i>stopexe</i>       | - | - | -  | -  | <i>reset</i>         | - | - | -  | -  |
| <i>wdreset</i>    | - | - | -  | -  |                      |   |   |    |    |                      |   |   |    |    |

### 7.10. BIT definition

- (1) Bit defined: Only addressed at 0x00 ~ 0x0F
- (2) WORD defined: Only addressed at 0x00 ~ 0x1E

### 8. Code Options

| Option         | Selection | Description  |
|----------------|-----------|--|
| Security       | Enable    | OTP content is protected and program cannot be read back |
|                | Disable   | OTP content is not protected so program can be read back |
| LVR            | 4.0V      | Select LVR = 4.0V  |
|                | 3.5V      | Select LVR = 3.5V  |
|                | 3.0V      | Select LVR = 3.0V  |
|                | 2.75V     | Select LVR = 2.75V                                       |
|                | 2.5V      | Select LVR = 2.5V  |
|                | 2.2V      | Select LVR = 2.2V  |
|                | 2.0V      | Select LVR = 2.0V  |
|                | 1.8V      | Select LVR = 1.8V  |
| Boot-up_Time   | Slow      | Please refer to $t_{WUP}$ and $t_{SBP}$ in Section 4.1   |
|                | Fast      | Please refer to $t_{WUP}$ and $t_{SBP}$ in Section 4.1   |
| PA5 Open-Drain | Enable    | PA5 as open drain mode (ICE does NOT Support.)           |
|                | Disable   | PA5 as normal IO mode                                    |



## 9. Special Notes

This chapter is to remind user who use PMS15B/PMS150G series IC in order to avoid frequent errors upon operation.

### 9.1. Using IC

#### 9.1.1. IO pin usage and setting

- (1) IO pin as digital input
  - ◆ When IO is set as digital input, the level of  $V_{ih}$  and  $V_{il}$  would changes with the voltage and temperature. Please follow the minimum value of  $V_{ih}$  and the maximum value of  $V_{il}$ .
  - ◆ The value of internal pull high resistor would also changes with the voltage, temperature and pin voltage. It is not the fixed value.
- (2) If IO pin is set to be digital input and enable wake-up function
  - ◆ Configure IO pin as input
  - ◆ Set corresponding bit to “1” in PADIER
  - ◆ For those IO pins of PA that are not used, PADIER[1:2] should be set low in order to prevent them from leakage.
- (3) PA5 set to Open-Drain pin or normal I/O pin
  - ◆ User can set PA5 as an open-drain output pin or normal I/O pin by using the Code Option PA5 Open-Drain: enable/disable.
  - ◆ The PA5 pin is equipped with a pull up ESD protection diode, so it is not a real OD pin. Please pay more attention to avoid current backfilling when it is used for Open-Drain mode.
- (4) PA5 is set to be PRSTB input pin
  - ◆ Configure PA5 as input
  - ◆ Set CLKMD.0=1 to enable PA5 as PRSTB input pin
- (5) PA5 is set to be input pin and to connect with a push button or a switch by a long wire
  - ◆ Needs to put a  $>33\Omega$  resistor in between PA5 and the long wire
  - ◆ Avoid using PA5 as input in such application.

#### 9.1.2. Interrupt

- (1) When using the interrupt function, the procedure should be:
  - Step1: Set INTEN register, enable the interrupt control bit
  - Step2: Clear INTRQ register
  - Step3: In the main program, using ENGINT to enable CPU interrupt function
  - Step4: Wait for interrupt. When interrupt occurs, enter to Interrupt Service Routine
  - Step5: After the Interrupt Service Routine being executed, return to the main program

\* Use DISGINT in the main program to disable all interrupts

\* When interrupt service routine starts, use PUSHAF instruction to save ALU and FLAG register. POPAF instruction is to restore ALU and FLAG register before RETI as below:

```
void Interrupt (void) // Once the interrupt occurs, jump to interrupt service routine
{ // enter DISGINT status automatically, no more interrupt is accepted
    PUSHAF;
    ...
    POPAF;
} // RETI will be added automatically. After RETI being executed, ENGINT status will be restored.
```

(2) INTEN and INTRQ have no initial values. Please set required value before enabling interrupt function.

### 9.1.3. System clock switching

System clock can be switched by CLKMD register. Please notice that, NEVER switch the system clock and turn off the original clock source at the same time. For example: When switching from clock A to clock B, please switch to clock B first; and after that turn off the clock A oscillator through CLKMD.

- ◆ Example : Switch system clock from ILRC to IHRC/8  
 CLKMD = 0x3C; // switch to IHRC, *ILRC can not be disabled here*  
 CLKMD.2 = 0; // ILRC can be disabled at this time
- ◆ **ERROR:** Switch ILRC to IHRC/8 and turn off ILRC simultaneously  
 CLKMD = 0x38; // MCU will hang

### 9.1.4. Power down mode, wakeup and watchdog

Watchdog will be inactive once ILRC is disabled.

### 9.1.5. TIMER time out

When select \$ INTEGS BIT\_R (default value) and T16M counter BIT8 to generate interrupt, if T16M counts from 0, the first interrupt will occur when the counter reaches to 0x100 (BIT8 from 0 to 1) and the second interrupt will occur when the counter reaches 0x300 (BIT8 from 0 to 1). Therefore, selecting BIT8 as 1 to generate interrupt means that the interrupt occurs every 512 counts. Please notice that if T16M counter is restarted, the next interrupt will occur once Bit8 turns from 0 to 1.

If select \$ INTEGS BIT\_F (BIT triggers from 1 to 0) and T16M counter BIT8 to generate interrupt, the T16M counter changes to an interrupt every 0x200/0x400/0x600/. Please pay attention to two differences with setting INTEGS methods.

### 9.1.6. IHRC

- (1) The IHRC frequency calibration is performed when IC is programmed by the writer.
- (2) Because the characteristic of the Epoxy Molding Compound (EMC) would some degrees affects the IHRC frequency (either for package or COB), if the calibration is done before molding process, the actual IHRC frequency after molding may be deviated or becomes out of spec. Normally, the frequency is getting slower a bit.

- (3) It usually happens in COB package or Quick Turnover Programming (QTP). And PADAUK would not take any responsibility for this situation.
- (4) Users can make some compensatory adjustments according to their own experiences. For example, users can set IHRC frequency to be 0.5% ~ 1% higher and aim to get better re-targeting after molding.

### 9.1.7. LVR

LVR level selection is done at compile time. User must select LVR based on the system working frequency and power supply voltage to make the MCU work stably.

The following are Suggestions for setting operating frequency, power supply voltage and LVR level:

| SYCLK | VDD         | LVR         |
|-------|-------------|-------------|
| 2MHz  | $\geq 1.8V$ | $\geq 1.8V$ |
| 4MHz  | $\geq 2.2V$ | $\geq 2.2V$ |
| 8MHz  | $\geq 3.0V$ | $\geq 3.0V$ |

Table 7: LVR setting for reference

- (1) The setting of LVR (1.8V ~ 4.0V) will be valid just after successful power-on process.
- (2) User can set MISC.2 as "1" to disable LVR. However,  $V_{DD}$  must be kept as exceeding the lowest working voltage of chip; Otherwise IC may work abnormally.
- (3) The LVR function will be invalid when IC in stopexe or stopsys mode.

### 9.1.8. Program writing

There are 6 pins for using the writer to program: PA3, PA4, PA5, PA6, VDD and GND.

Please use 5S-P-003 or above Writer to program PMS15B/PMS150G, and follow the instructions shown in the Writer software for jumper connecting. 5S-P-002 or older versions do not support programming this IC.

- Special notes about voltage and current while Multi-Chip-Package(MCP) or On-Board Programming
  - (1) PA5 ( $V_{PP}$ ) may be higher than 7.5V.
  - (2)  $V_{DD}$  may be higher than 7.8V, and its maximum current may reach about 20mA.
  - (3) All other signal pins level (except GND) are the same as  $V_{DD}$ .

User should confirm when using this product in MCP or On-Board Programming, the peripheral components or circuit will not be damaged by the above voltages, and will not clamp the above voltages.

#### Important Cautions:

- You MUST follow the instructions on APN004 and APN011 for programming IC on the handler.
- Connecting a 0.01uF capacitor between VDD and GND at the handler port to the IC is always good for suppressing disturbance. But please DO NOT connect with  $>0.01uF$  capacitor, otherwise, programming may be fail.
- Please concatenate a 100Ω resistance to the PA5 of JP2 or JP7 on the back of the writer before writing IC, and refer to APN016 for specific operations. The 5S-P-003x writer will be provided with this adapter. If you have any needs or problems in use, you can contact us fae@padauk.com.tw.

# PMS15B/PMS150G Family 8 bit OTP Type IO Controller

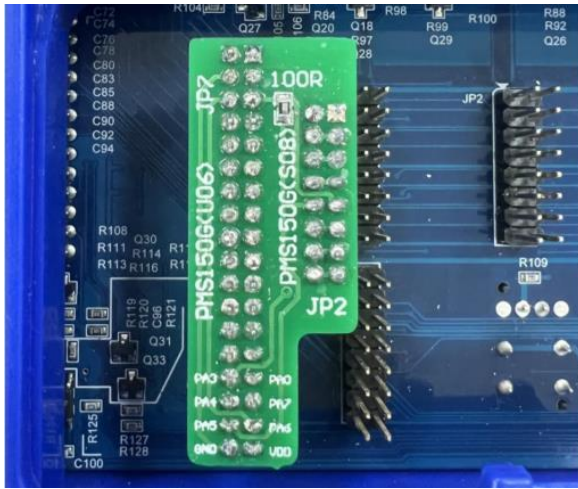

Fig. 14: JP7 Physical connection diagram



Fig. 15: JP2 Physical connection diagram

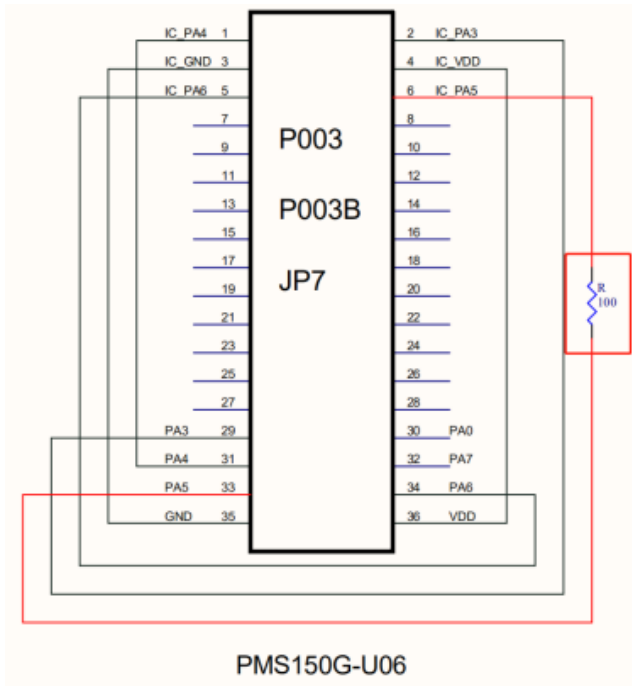

Fig. 16: JP7 connection schematic diagram

- Due to the difference between the new and old wafer versions of PMS15B/PMS150G, if the user meets the NG prompt of “IC Ver Mismatch” during programming the chip, which means the chip used is an old version. At this time, lowering the system clock to 2MHz or below may solve this problem. But the old version IC can also run the system clock of 2MHz and above when the stopexe or stopsys instruction is not used in the program.

### 9.2. Using ICE

Please use 5S-I-S01/2(B) ICE to emulate most of PMS15B/PMS150G function except as the list below:

- (1) 5S-I-S01/2(B) doesn't support  $SYSCLK=ILRC/16$
- (2) 5S-I-S01/2(B) doesn't support PA6 and PA7 as the CIN- of the comparator, please connect to the PB6 or PB7 for CIN- input when simulating. In actual chip it still in PA6/PA7.
- (3) 5S-I-S01/2(B) doesn't support TM2PWM output of PA4, please connect to the PB4 for measuring PWM waveform when simulating. In actual chip it still in PA4.
- (4) 5S-I-S01/2(B) doesn't support the INTEGS the Bit[7:6] dynamically switched.
- (5) 5S-I-S01/2(B) doesn't support pull-low simulation.
- (6) When  $GPCS[7]=1$ , the output of PA0 will affect the High function of PA3.
- (7) When simulating PWM waveform, please check the waveform during program running. When the ICE is suspended or single-step running, its waveform may be inconsistent with the reality.
- (8) When using 5S-I-S01/2(B) for simulation, changing the value of  $tm2ct$  will affect the duty during timer2 period mode. But it will not be affected for the actual IC.
- (9) With 5S-I-S01/2(B) simulation, when fast wake-up is enabled, the watchdog overflow reset time becomes very short. Actually, it has not effect on IC.
- (10) The ILRC frequency of the 5S-I-S01/2(B) simulator is different from the actual IC and is uncalibrated, with a frequency range of about 34K~38KHz.
- (11) Fast Wakeup time is different from 5S-I-S01/2(B): 128 SysClk, PMS15B/PMS150G: 32 ILRC
- (12) Watch dog time out period is different from 5S-I-S01/2(B):

| WDT period     | PMS15B/PMS150G    | 5S-I-S01/2(B)      |
|----------------|-------------------|--------------------|
| $misc[1:0]=00$ | $8K * T_{ILRC}$   | $2048 * T_{ILRC}$  |
| $misc[1:0]=01$ | $16K * T_{ILRC}$  | $4096 * T_{ILRC}$  |
| $misc[1:0]=10$ | $64K * T_{ILRC}$  | $16384 * T_{ILRC}$ |
| $misc[1:0]=11$ | $256K * T_{ILRC}$ | $256 * T_{ILRC}$   |