



5S-P-003X

Program Writer

User Manual

Version 0.08 – May 26, 2026

Copyright © 2026 by PADAUK Technology Co., Ltd., all rights reserved.

IMPORTATNT STATEMENT

PADAUK Technology reserves the right to make changes to its products or to terminate production of its products at any time without notice. Customers are strongly recommended to contact PADAUK Technology for the latest information and verify whether the information is correct and complete before placing orders.

PADAUK Technology products are not warranted to be suitable for use in life-support applications or other critical applications. PADAUK Technology assumes no liability for such applications. Critical applications include, but are not limited to, those which may involve potential risks of death, personal injury, fire or severe property damage.

PADAUK Technology assumes no responsibility for any issue caused by a customer's product design. Customers should design and verify their products within the ranges guaranteed by PADAUK Technology. In order to minimize the risks in customers' products, customers should design a product with adequate operating safeguards.

Table of Contents

Revision History:	4
1. About 5S-P-003X Writer	5
1.1. The front	5
1.2. The back.....	6
1.3. The side face	6
1.4. Accessories of Program Writer.....	7
1.5. Writing application software and User Manual	7
2. Functional Description	8
2.1. Steps of loading File.....	9
2.2. Blank Check.....	10
2.3. Verify.....	10
2.4. Auto Program.....	10
2.5. Rolling Code	12
2.6. Read & Search	13
2.7. Convert PDK.....	13
3. Version Update	14
3.1. Automatic update	14
3.2. Manual update	15
4. JUMPER Description	16
4.1. Examples	16
5. Connecting Board Making Description	16
5.1. Define the data of exclusive use packaged pin.....	17
5.2. Connecting Board making	18
5.3. Case 1	19
5.4. Case 2 (Customized package pin)	21
5.5. The way to add package pin information to PDK file	23
5.6. The description of package setting details.....	24
6. Semi-automatic Writing Handler Connection Description	25
7. Set O/S Test and Blank Check	26
8. Writer LCM Information and Buzzer Sound Table	28
9. Appendix Descriptions	30
9.1 The difference between 5S-P-003 and 3S-P-002.....	30
9.2 The difference between 5S-P-003 and 5S-P-003BX.....	30
9.2 Special notes of MTP On-board writing	30
9.3 Special notes of voltage while On-board or Multi-Chip-IC writing (OTP / MTP)	32

Revision History:

Revision	Date	Description
0.07	2022/10/14	<ol style="list-style-type: none"> 1. Update pictures and contents of accessories 2. Update the To Package operation UI picture and add the command option 3. Update LCDM display picture content 4. Update UI picture of on-board writing 5. Supplementary instructions for Manual update 6. Update picture of semi-automatic writing connection
0.08	2026/05/26	<ol style="list-style-type: none"> 1. Update 5S-P-003 to 5S-P-003X 2. Optimize Figure 1.2 3. Modify the .writer package format in Section 5.1 4. Update descriptions for Sections 5.3 & 5.4

1. About 5S-P-003X Writer

1.1. The front

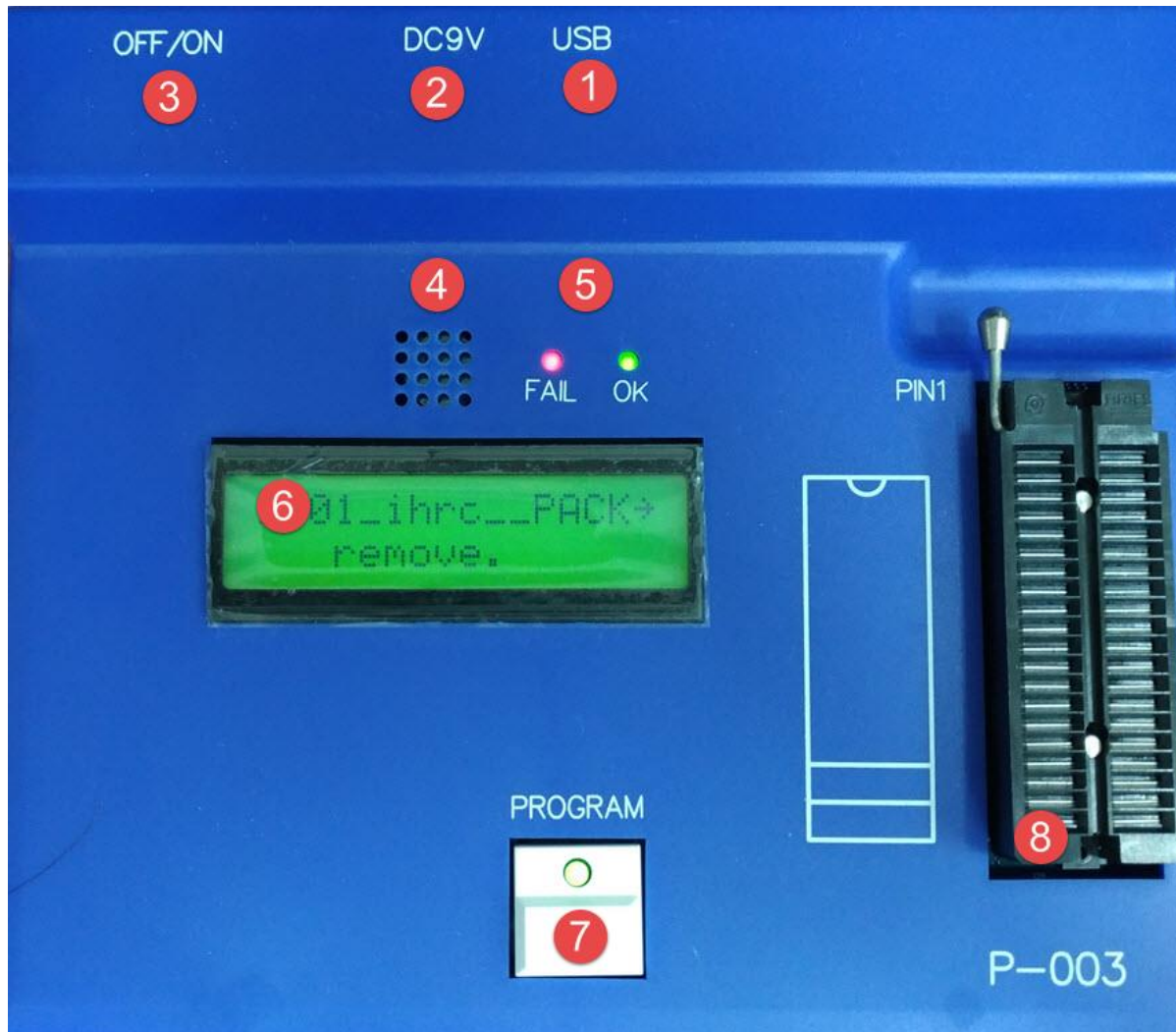

- (1) USB interface: Connect to PC.
- (2) Power interface: Please use the exclusive power converter of Program Writer accessories.
(Do not use other power converters to avoid damaging the Program Writer)
- (3) Power Switch: OFF/ON.
- (4) Buzzer: Be used as alarm while failed to write.
- (5) LED (OK & NG) lamp: Display the result of writing.
- (6) LCM displayer: Display the information and result of writing.
- (7) Program button: Start writing.
- (8) Textool: Suitable for DIP package (available for 28 PIN at most).

1.2. The back

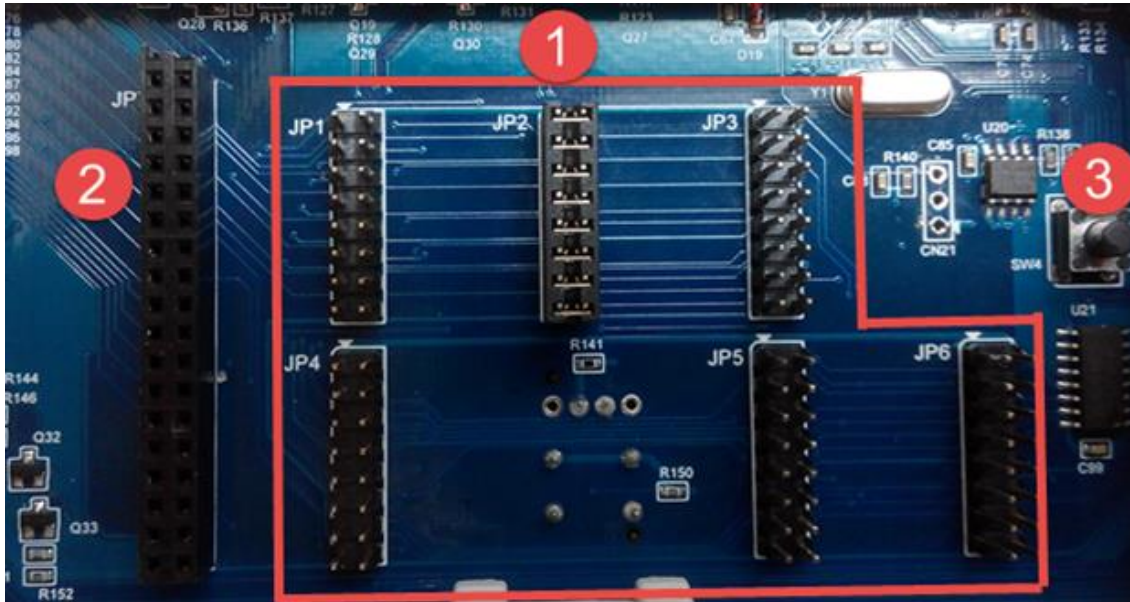

- (1) JUMPER (JP1~JP6): Different IC or package would coordinate with different JUMPER position. Please refer to chapter 4.
- (2) JUMPER (JP7): When it comes to non-standard or unusual package, you need to use JP7 to transform relevant information. About Connecting Board making, please refer to chapter 5.
- (3) Forced update mode button: Forcing update the current version, please refer to section 3.1

1.3. The side face



- (1) USB interface: Connect to PC.
- (2) Power interface: Please use the exclusive power converter of Program Writer. **(Do not use other power converters to avoid damaging the Program Writer)**
- (3) Power Switch: OFF/ON.
- (4) Semi-automatic writing connection port: About the connection method, please refer to chapter 6.

1.4. Accessories of Program Writer



- (1) The exclusive power converter.
- (2) The USB cable.
- (3) 150G adapter plate.

1.5. Writing application software and User Manual

You can download the latest version of the application software at the following address (including the latest version of the Program Writer)

<http://www.padauk.com.tw/en/technical/index.aspx?kind=27>

Or enter the home page of www.padauk.com.tw, obtain latest Program Writer version from [home page > technology application > technology development tool > Program Writer](#). Please refer to the chapter 3.

2. Functional Description

(A) Engineering type

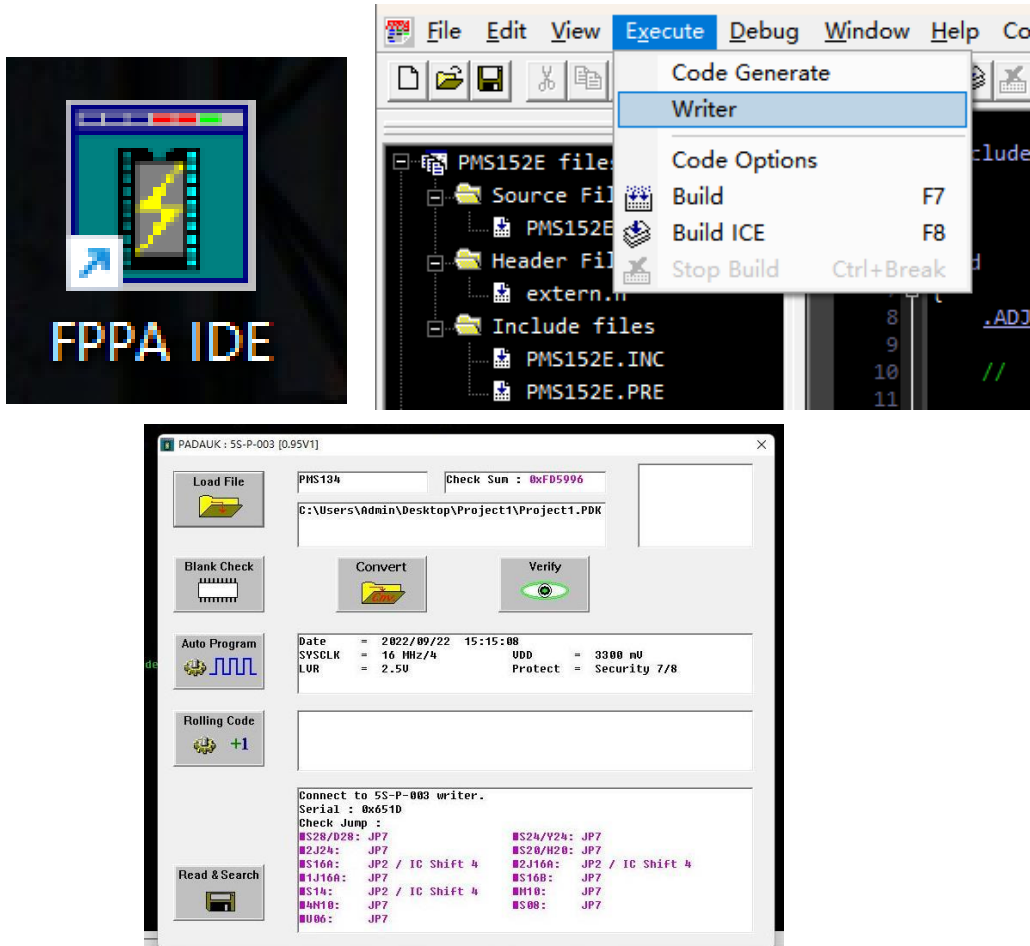

(B) Simple type

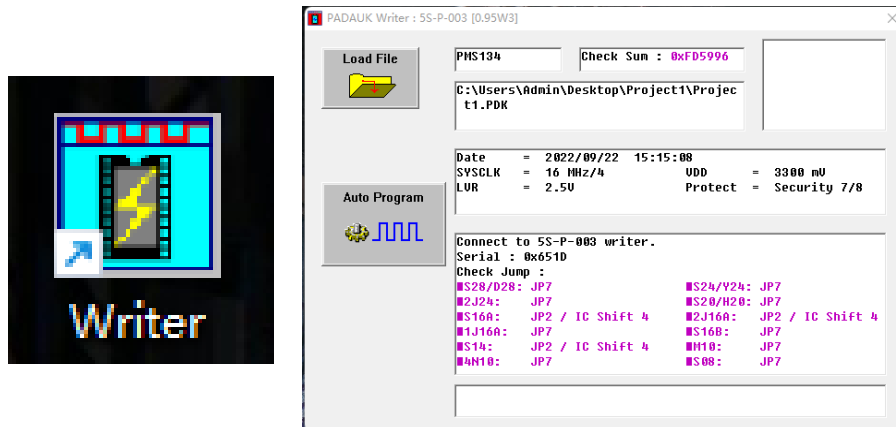

No matter simple type or engineering type, they have the equal corresponding function.

2.1. Steps of loading File

- (1) Load PDK file from PC to Program Writer.
- (2) Related information of PDK file would be displayed after loading successfully. (i.e. Check Sum, file name ...)

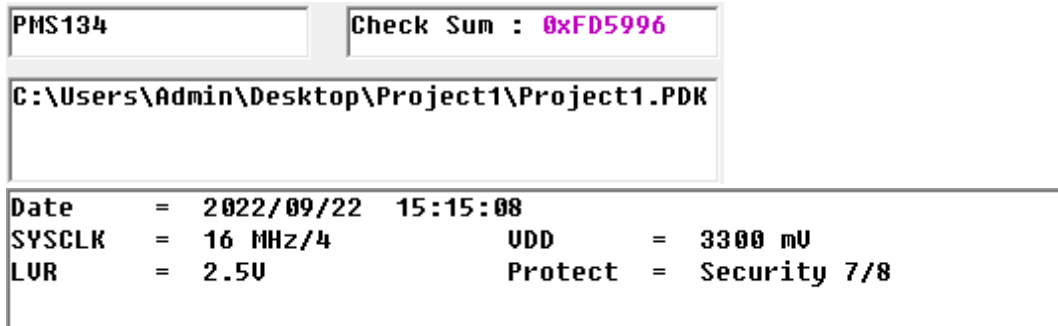

- (3) After loading successfully, the JUMPER position and IC placement would be prompted.

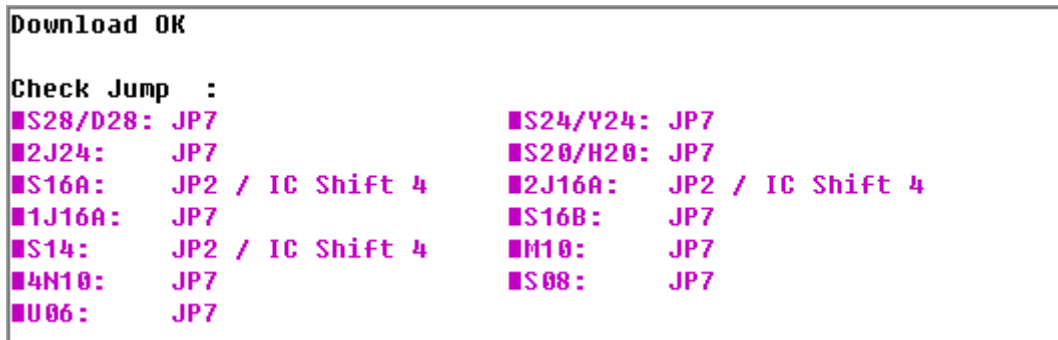

- (4) The LCM also displays the messages and prompts synchronously.



- (5) Users could also unplug the USB cable and write in alone mode after the file loaded successfully.
- (6) Users should make sure that the jumper and IC have been placed in the correct positions before starting "Blank Check," "Verify," "Read & Search," and "Auto Program" actions.
- (7) About JUMPER & IC placement position, please refer to "JUMPER Description".
- (8) When JUMPER & IC have been placed, the Program Writer's LCM displays "IC ready".



2.2. Blank Check

Check whether the IC content is blank or not.

2.3. Verify

Check whether the IC and the .PDK file have the same content.

2.4. Auto Program

Start writing automatically.

- It is equal to press the Program Writer's PROGRAM button.
- The actions include: Programmable check → Program → Verify → Protect and so on.
- When write successfully, the Program Writer displays “<<<< IC O.K. >>>>” on the LCM.
- Examples of writing (including the position of JUMPER and IC placement).

Take the follow PDK file and IC for examples.

File	IC	Jumper	IC Shift	Note
Project1.PDK	PMS134-S16A	JP2	4	

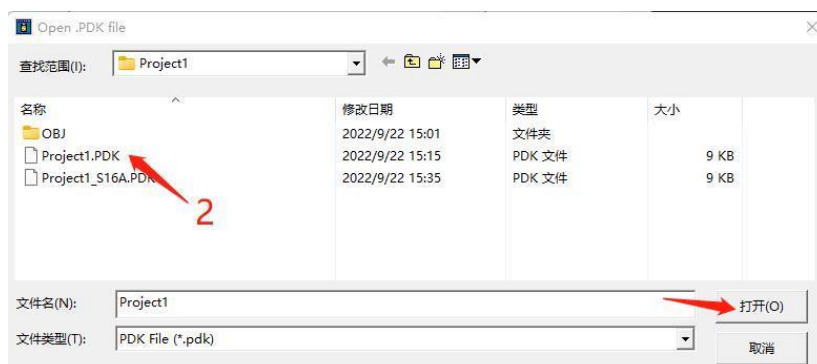
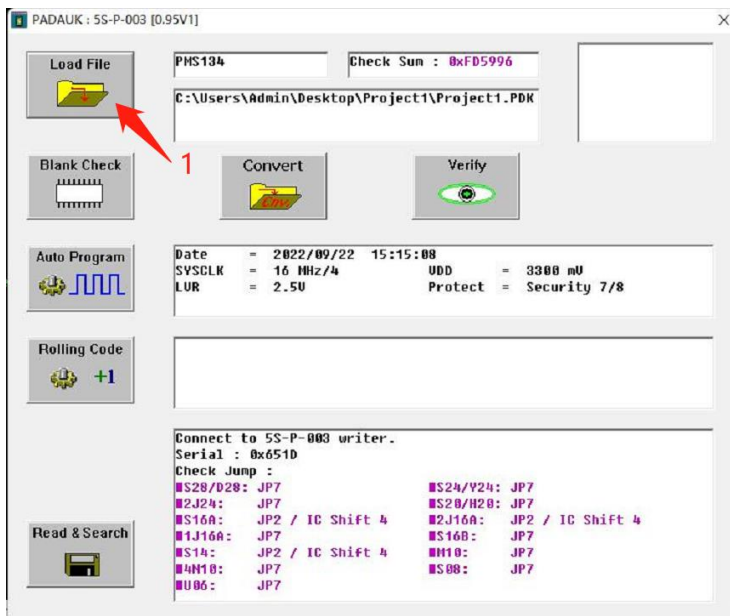

- (1) Click on 『 Load File 』
- (2) Choose JP2_83K.PDK, click on “打开”

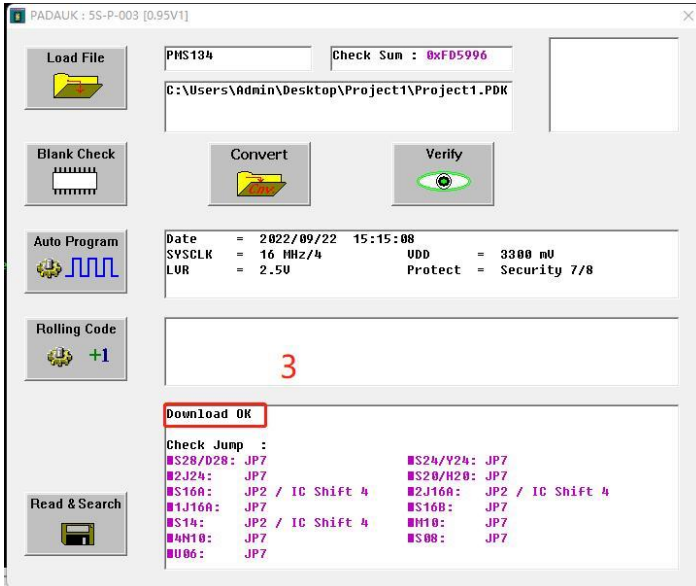

- (3) Confirm Download OK (notice the message)
- (4) Confirm the information displayed on LCM.

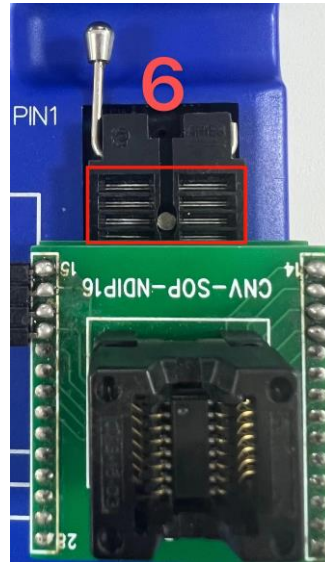

- (5) Insert JUMPER into JP2 according to the information of (3) or (4).
- (6) Place IC according to the information of (3) or (4).” IC Shift: 4 ” - means shift four blank space from the top.
- (7) Make sure the information ”IC Ready” displayed on LCM.

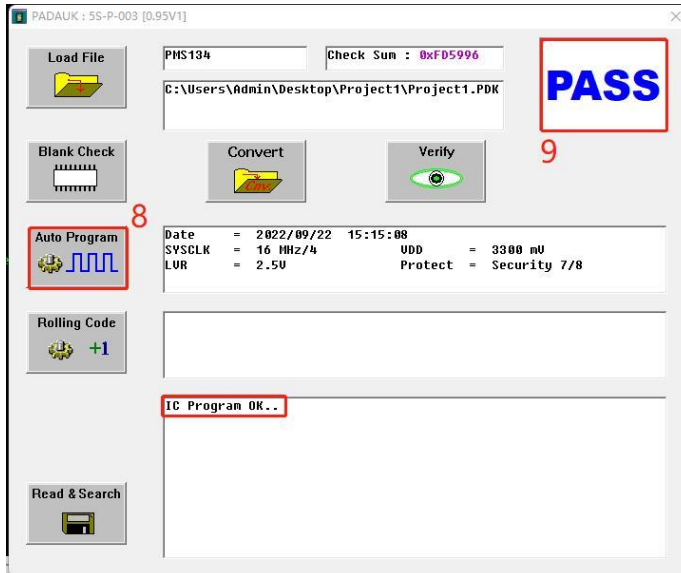

- (8) Click on ”Auto Program” to start writing.
- (9) Make sure the writing result is ” PASS ”.
- (10) Make sure the information ”<<< IC O.K. >>>” displayed on LCM.

2.5. Rolling Code

Start the relevant settings about Rolling Code, settings include:

- (1) Initial value.
- (2) Incremental value.

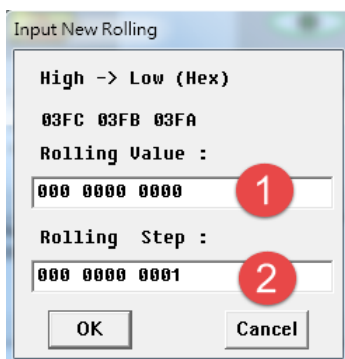

- This function only valid while the Rolling Code grammar has been set in the loading PDK file
- Please refer to the IDE User Manual to learn about the ways of setting Rolling Code.

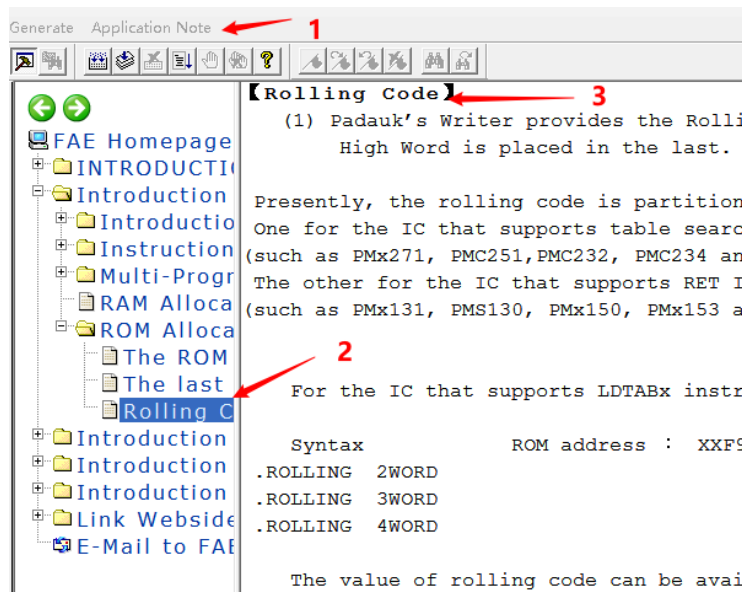

- (1) Click on "Application Note"
- (2) Click on "IC introduction" → "ROM distribution" → "Roll_Code".
- (3) Look up the ways of Rolling Code.

2.6. Read & Search

Search for PC's PDK file which has the same CHECK-SUM.

2.7. Convert PDK

- (1) Confirm the PDK file is the one need to convert.
- (2) Start converting PDK file.

3. Version Update

You can download the latest version of the application software and Manual (including the latest version of the Program Writer) at the following address:

<http://www.padauk.com.tw/en/technical/index.aspx?kind=27>

Or by www.padauk.com.tw website [home page](#) > [technology application](#) > [technology development tool](#) > [Program Writer](#) obtains.

After download the application software, you can install it. Then, you should make sure the Program Writer is connected to PC when update its version. Besides, the Program Writer will update automatically at the first execution.

3.1. Automatic update

While execute the application software, the auto-updating application software including the Program Writer version.

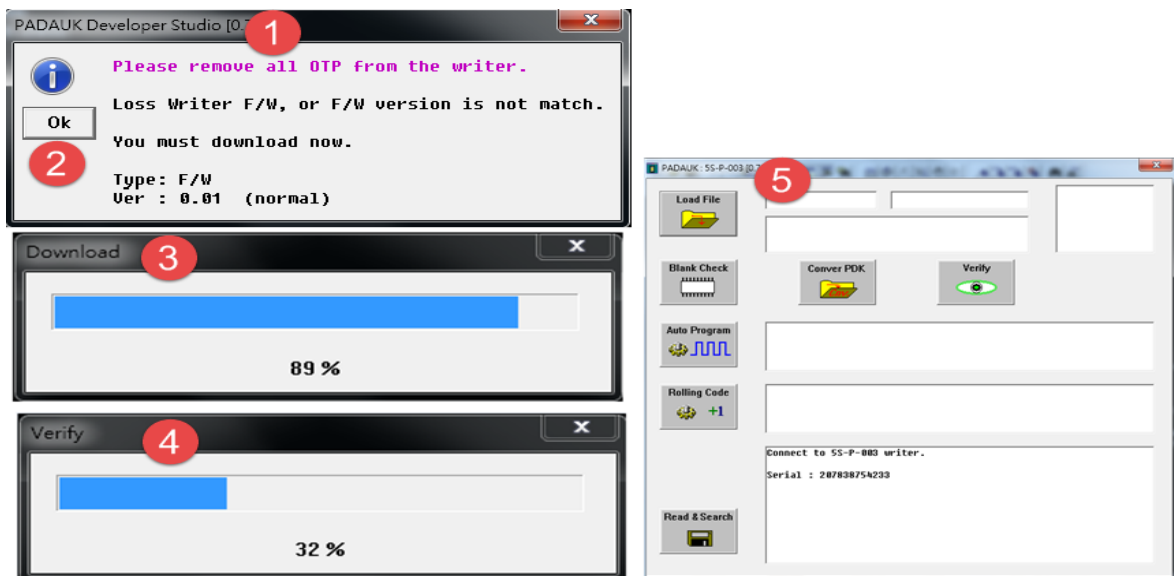

- (1) The prompting of Program Writer version update
- (2) Click on "OK" to start updating
- (3) Download the new version in Program Writer.
- (4) Verify the new version.
- (5) Connect to PC automatically after finish

NOTICE: Please update manually if there is no auto- update when the first time to execute the application software.

3.2. Manual update

Manual mandatory updates are recommended when service calls occur for burner P003Bx LCDM.

- (1) Shut down and hold the forced update mode button (SW3) on the back of the writer.

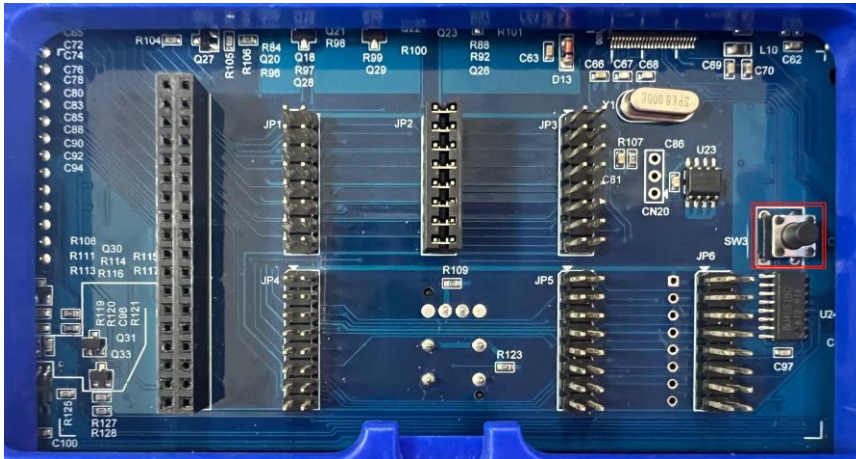

- (2) Turn on the power supply, release the SW3 key, enter the Boot loader mode, FAIL light and OK light on at the same time, the LCM displays the following information:



- (3) Execute the writing application software and force the update of the writer version contained in the application software. Click OK and the software will automatically Download and Verify.

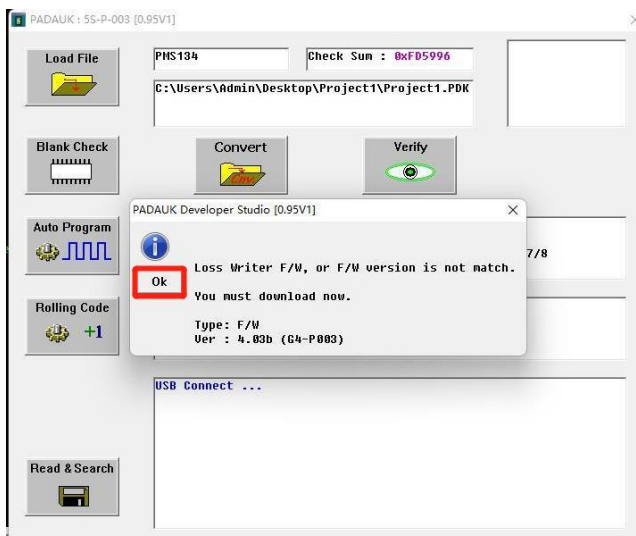

4. JUMPER Description

4.1. Examples

After PDK file is loaded to Program Writer, the window displays the IC's information concerning Jumper position and the number of needed spaces. As shown in the following picture: (Take PMS154B as an example)

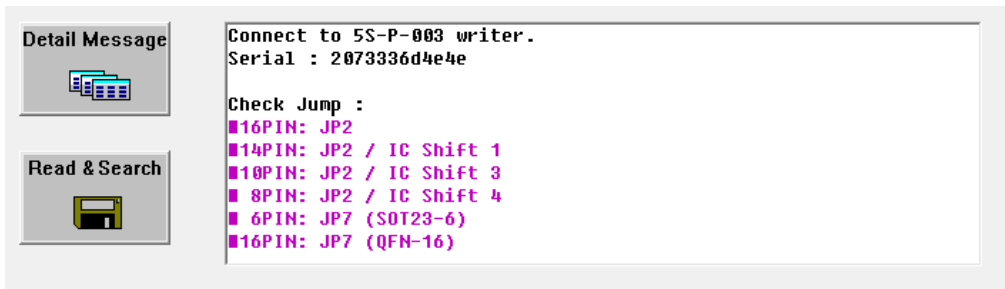

- SOP16/DIP16 standard package: Jumper is placed in "JP2" position which on the back of Writer and IC is placed in Textool (no shifts). As shown in the following pictures:

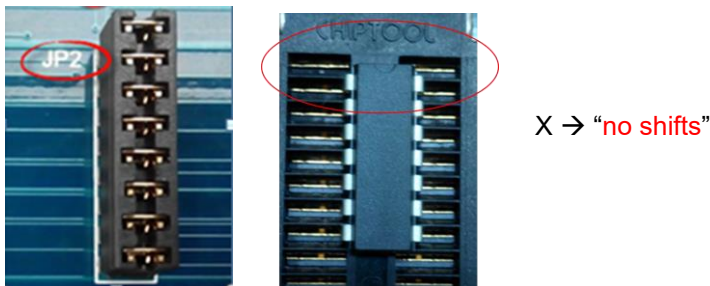

- SOP14 standard package: Jumper is placed in "JP2" position which on the back of Writer; IC is placed from the second space of Textool. As shown in the following pictures:

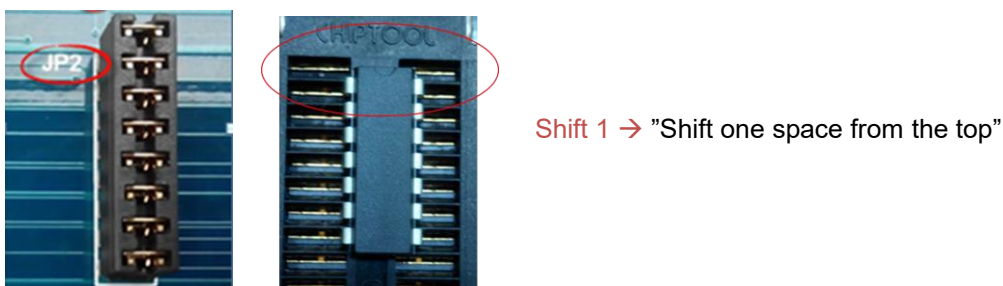

Note: As for non-standard and unusual IC package, need be connected to JP7 through Connecting Board. Please refer to 『Connecting Board Making』 to learn about Connecting Board.

5. Connecting Board Making Description

JP7 can support various customizing package pin based on Connecting Board.

The making and rules of the Connecting Board as follows:

- (1) Define the information of package pin in program.
- (2) Make the Connecting Board.
- (3) For developed PDK files, adding the information of package pin please refer to section 5.5.

5.1. Define the data of exclusive use packaged pin

Define the data of exclusive use packaged pin in program. Here is grammar:

.writer package, (A total of thirteen sets of values)

For example: **.writer package** 16, 5, 11, 9, 10, 8, 7, 6, 14, 0, 0, 0x00F0, 0x00F4, 0x00, 0x04

Grammar instruction:

Group Count	Name	Introduction	Remarks
1	Pin Count	(the number of pin)	Up to 28 pins
2	VDD	VDD pin number	
3	PA0	PA0 pin number	Note 1
4	PA3	PA3 pin number	
5	PA4	PA4 pin number	
6	PA5	PA5 pin number	
7	PA6	PA6 pin number	
8	PA7	PA7 pin number	Note 1
9	GND	GND pin number	
10	AVDD	Analog VDD pin number	Note 1
11	AGND	Analog GND pin number	Note 1
12	Mask1	Package the left pin mask value, each bit represents a pin BIT0 → 1st pin, BIT2 → 2nd pin, BITn (n=0..13) 0/1: bypass / O/S test Set 0: this pin not do O/S test Set 1: this pin do O/S test	Note 2
13	Mask2	Package the right pin mask value, each bit represents a pin; BIT0 → m pin, BIT2 → (m-1)pin, BITn (n=0..13) 0/1: bypass/ O/S test Set 0: this pin not do O/S test Set 1: this pin do O/S test	m: The number of pin. Note 2
14	x / Shift	(1) X mean JPx used. X=1~7 (2) IC is corresponding to the blank space number need to shift from the top of SOCKET.	JPx: high nibble Shfit: low nibble
15	Option	Option Description	Bit2: Write on board Bit4: VDD/VPP swap Bit5: Write on board w/ self-power Others: Reserved

Note 1: If the pin does not exist, fill in 0 representing NC (no connect)

Note 2: If the pin does not exist or cannot do O/S test (i.e. Special multi-chip package pin), set the corresponding bit value to zero.

5.2. Connecting Board making

The JP7 last 8 pins are writing pins, as shown in the following figure:

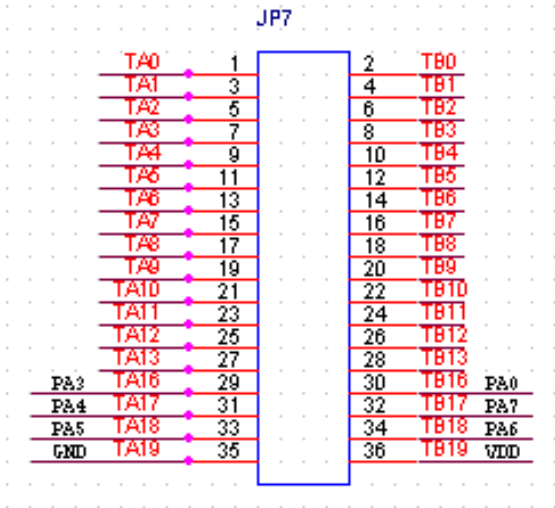

While making a Connecting Board, please decide the IC placement position (generally assumed that the first pin of IC is aligned with the upper left first pin of the Socket.) and connect the last 8 pins of Connecting Board with the corresponding pin of IC, as shown in the following figure:

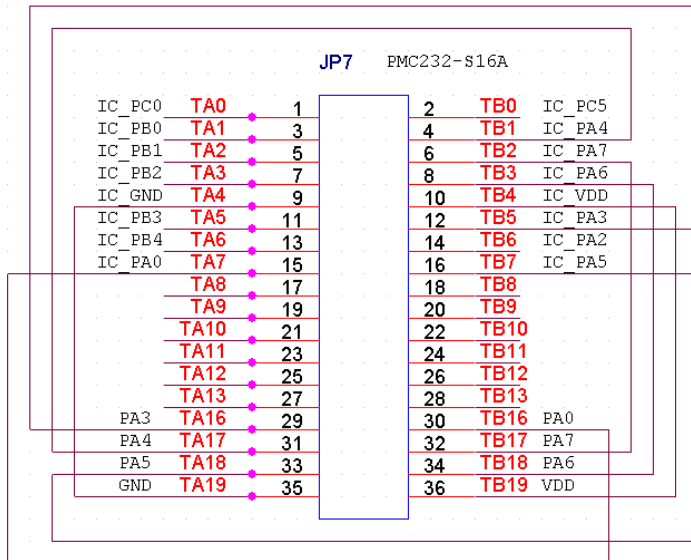

5.3. Case 1

Take PMx131 MSOP-10 for example:

IC	Package	Jumper	IC Shift	Note
PMx131	MSOP10	JP7	4	Please connect JP7 with Connecting Board.(Note1)

The PMx131 MSOP-10 package as follows:

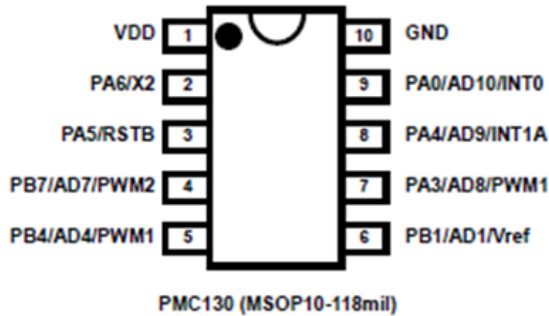

(1) You can use the following instruction to define the exclusive package pin:

.writer package 10, 1, 9, 7, 8, 3, 2, 0, 10, 0, 0, 0x003F, 0x003F, 0x74, 0x04

Group count	Name	Description	Value	Remarks
1	Pin Count	The number of package pin	10	
2	VDD	VDD pin serial number	1	
3	PA0	PA0 pin serial number	9	
4	PA3	PA3 pin serial number	7	
5	PA4	PA4 pin serial number	8	
6	PA5	PA5 pin serial number	3	
7	PA6	PA6 pin serial number	2	
8	PA7	PA7 pin serial number	0	0 indicates that PA7 does not exist
9	GND	GND pin serial number	10	
10	AVDD	AVDD pin serial number	0	0 indicates that AVDD does not exist
11	AGND	AGND pin serial number	0	0 indicates that AGND does not exist
12	Mask1	Package the left pin mask value	0x001F	All pin should test O/S.
13	Mask2	Package the right pin mask value	0x001F	All pin should test O/S.
14	X / Shift	(1) using JP7 (2) The blank space IC need to be shifted	0x74	(1) Using JP7 (2) IC first pin align to the upper left fifth pin of Socket
15	Option	Option Description	0x04	Bit2: Write on board Bit4: VDD/VPP swap Others: Reserved

(2) Make the Connecting Board

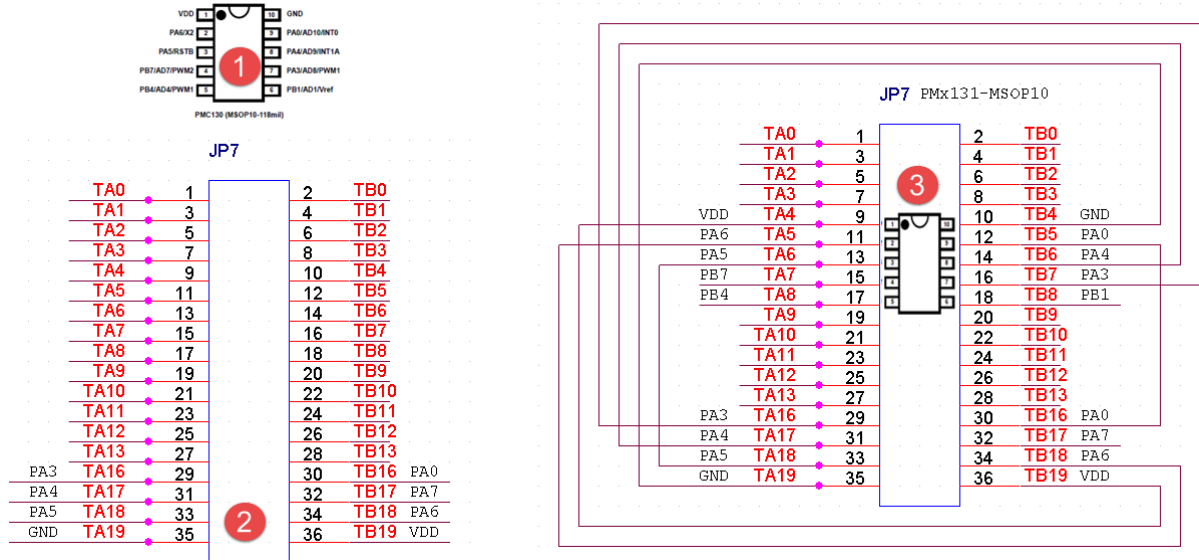

(1) Confirm the package pin of PMx131 MSOP-10

(2) Confirm the JP7 pin in the back of Writer

TA16 - PA3	TB16 - PA0
TA17 - PA4	TB17 - PA7
TA18 - PA5	TB18 - PA6
TA19 - GND	TB19 - VDD

(3) Put IC in SOCKET → put IC from the **fifth space** of SOCKET

According to the data below, connecting " VDD, GND, PA0,PA3,PA4,PA6,PA7 " with IC's corresponding pins.

TA16 (PA3)	-----	TB7(IC-PA3)
TA17 (PA4)	-----	TB6(IC-PA4)
TA18 (PA5)	-----	TA6(IC-PA5)
TA19 (GND)	-----	TB4(IC-GND)
TB16 (PA0)	-----	TB5(IC-PA0)
TB17 (PA7)	-----	NC
TB18 (PA6)	-----	TA5(IC-PA6)
TB19 (VDD)	-----	TA4(IC-VDD)

NOTICE: If the thirteenth group number (shift) is changed to 0, it means that the first pin of IC aligns the upper left first pin of Socket, at the same time all connection of corresponding IC pins have to be changed.

5.4. Case 2 (Customized package pin)

Customized package pins are shown in the following picture:

```

////////////////////////////////////
// Customer Package
////////////////////////////////////
// 1 X          16 GND
// 2 X          15 X
// 3 PB5        14 X
// 4 PB6        13 X
// 5 PB7        12 PA0
// 6 UDD        11 PA4
// 7 PA7        10 PA3
// 8 PA6         9 PA5
////////////////////////////////////

```

```

1      2  3  4  5  6  7  8  9  10  11  12  13  14  15
pin_cnt vdd pa0 pa3 pa4 pa5 pa6 pa7 gnd avdd agnd mask1 mask2 x/shift option

```

(1) You can use the following instruction to define the exclusive package pin:

```
.writer package 16, 6, 12, 10, 11, 9, 8, 7, 16, 0, 0, 0x00FC, 0x00F1, 0x70, 0x04
```

Group Count	Name	Description	Value	Remark
1	Pin Count	the number of pin	16	
2	VDD	VDD pin serial number	6	
3	PA0	PA0 pin serial number	12	
4	PA3	PA3 pin serial number	10	
5	PA4	PA4 pin serial number	11	
6	PA5	PA5 pin serial number	9	
7	PA6	PA6 serial number	8	
8	PA7	PA7 pin serial number	7	
9	GND	GND pin serial number	16	
11	AVDD	AVDD pin serial number	0	0 indicates that AVDD does not exist
12	AGND	AGND pin serial number	0	0 indicates that AGND does not exist
13	Mask1	Package the left pin mask value	0x00FC	Bypass pin 1, 2.
14	Mask2	Package the right pin mask value	0x00F1	Bypass pin 15, 14, 13
15	X / Shift	JP7 & The blank space IC need to be shifted	0x70	Using JP7 and The first pin of IC aligns the upper left first pin of Socket
13	Option	Option Description	0x04	Bit2: Write on board Bit4: VDD/VPP swap Others: Reserved

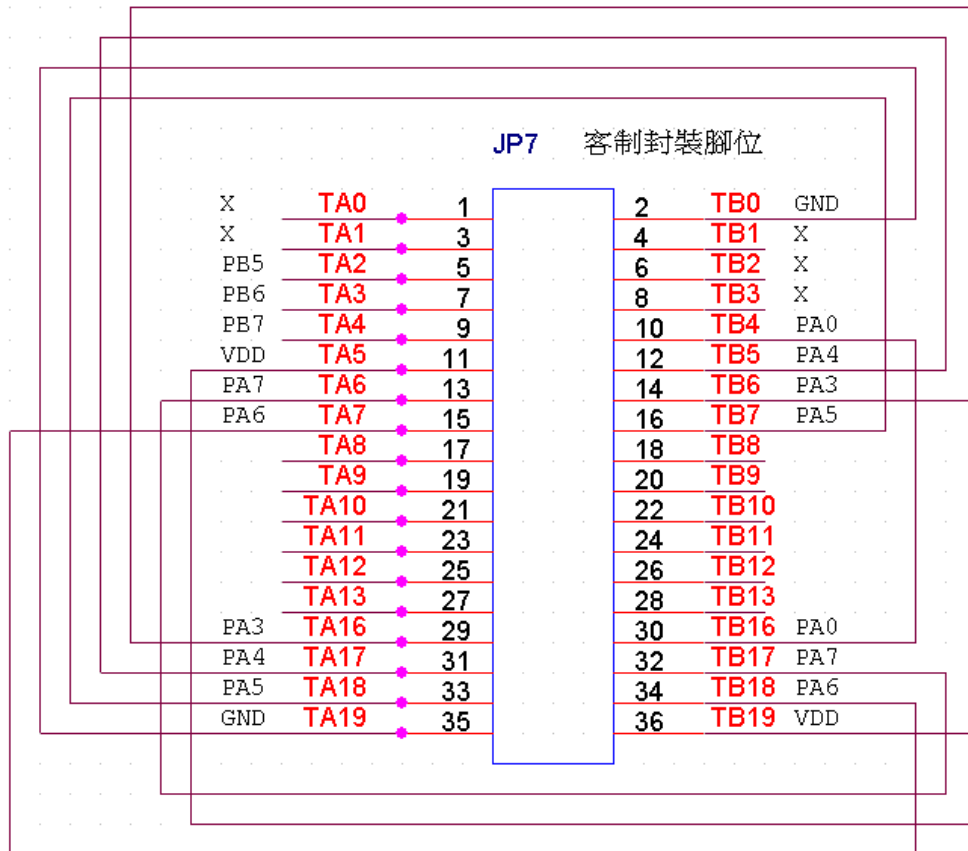

- (1) Confirm the package pins.
- (2) Confirm the JP7 pins on the back of Writer (TA16~TA19, TB16~TB19).

TA16 - PA3	TB16 - PA0
TA17 - PA4	TB17 - PA7
TA18 - PA5	TB18 - PA6
TA19 - GND	TB19 - VDD
- (3) Put IC in the SOCKET → put IC from the top of Socket (no space).
 According to the following table ,complete the connection between 『VDD、GND、PA0、PA3、PA4、PA6、PA7』 and IC's corresponding pins.

TA16 (PA3)	-----	TB7(IC-PA3)
TA17 (PA4)	-----	TB6(IC-PA4)
TA18 (PA5)	-----	TA6(IC-PA5)
TA19 (GND)	-----	TB4(IC-GND)
TB16 (PA0)	-----	TB5(IC-PA0)
TB17 (PA7)	-----	NC
TB18 (PA6)	-----	TA5(IC-PA6)
TB19 (VDD)	-----	TA4(IC-VDD)

5.5. The way to add package pin information to PDK file

For the developed PDK file, the way to add package pin information as follows:

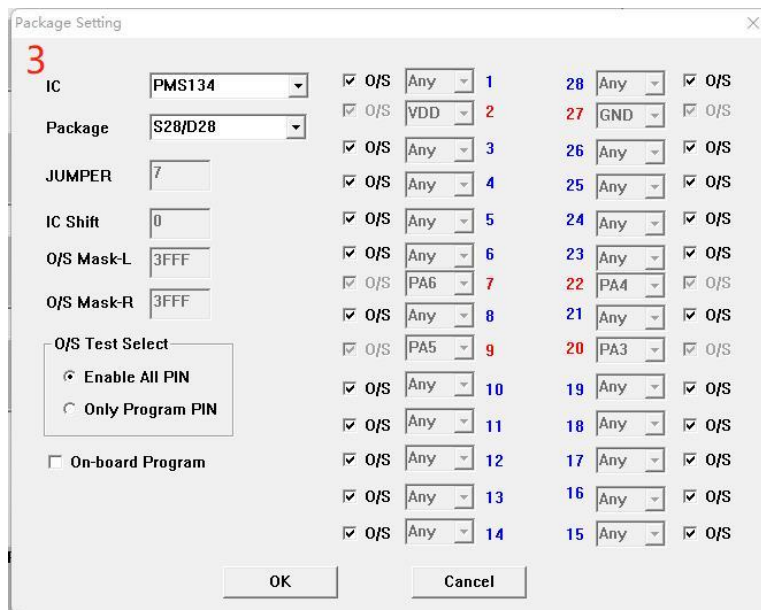
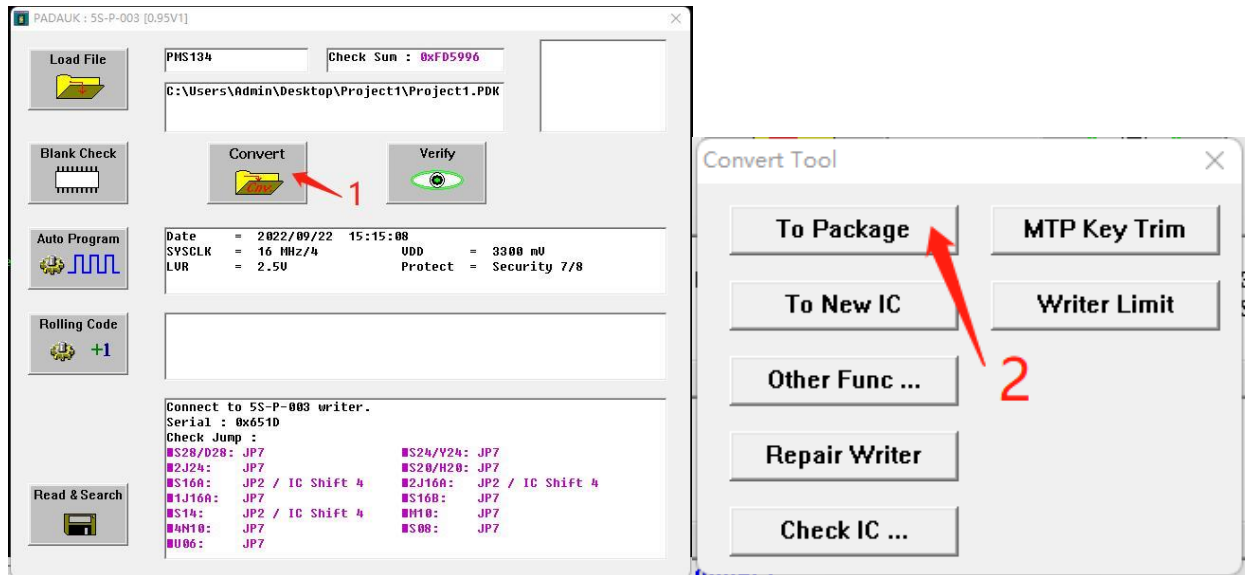

- (1) Click on "Convert PDK".
- (2) Choose "To Package".
- (3) Insert the information of package pin, please refer to section 5.1 for format.
- (4) Click on "OK".
- (5) Confirm again.
- (6) Save as a new file.

5.6. The description of package setting details

Package Setting

IC: PMS134

Package: User define, PMS134

JUMPER: 7

IC Shift: 0

O/S Mask-L: 3FFF

O/S Mask-R: 3FFF

O/S Test Select

- Enable All PIN
- Only Program PIN

On-board Program

<input checked="" type="checkbox"/> O/S	Any	1	28	Any	<input checked="" type="checkbox"/> O/S
<input checked="" type="checkbox"/> O/S	VDD	2	27	GND	<input checked="" type="checkbox"/> O/S
<input checked="" type="checkbox"/> O/S	Any	3	26	Any	<input checked="" type="checkbox"/> O/S
<input checked="" type="checkbox"/> O/S	Any	4	25	Any	<input checked="" type="checkbox"/> O/S
<input checked="" type="checkbox"/> O/S	Any	5	24	Any	<input checked="" type="checkbox"/> O/S
<input checked="" type="checkbox"/> O/S	Any	6	23	Any	<input checked="" type="checkbox"/> O/S
<input checked="" type="checkbox"/> O/S	PA6	7	22	PA4	<input checked="" type="checkbox"/> O/S
<input checked="" type="checkbox"/> O/S	Any	8	21	Any	<input checked="" type="checkbox"/> O/S
<input checked="" type="checkbox"/> O/S	PA5	9	20	PA3	<input checked="" type="checkbox"/> O/S
<input checked="" type="checkbox"/> O/S	Any	10	19	Any	<input checked="" type="checkbox"/> O/S
<input checked="" type="checkbox"/> O/S	Any	11	18	Any	<input checked="" type="checkbox"/> O/S
<input checked="" type="checkbox"/> O/S	Any	12	17	Any	<input checked="" type="checkbox"/> O/S
<input checked="" type="checkbox"/> O/S	Any	13	16	Any	<input checked="" type="checkbox"/> O/S
<input checked="" type="checkbox"/> O/S	Any	14	15	Any	<input checked="" type="checkbox"/> O/S

OK Cancel

Package Setting

1 IC: User define

2 Package: User set

JUMPER: 7 PIN: 16

3 IC Shift: 0

O/S Mask-L: 00FF

O/S Mask-R: 00FF

7 O/S Test Select

- Enable All PIN
- Only Program PIN

On-board Program

<input checked="" type="checkbox"/> O/S	VDD	1	16	Any	<input checked="" type="checkbox"/> O/S
<input checked="" type="checkbox"/> O/S	PA0	2	15	Any	<input checked="" type="checkbox"/> O/S
<input checked="" type="checkbox"/> O/S	PA3	3	14	GND	<input checked="" type="checkbox"/> O/S
<input checked="" type="checkbox"/> O/S	Any	4	13	PA6	<input checked="" type="checkbox"/> O/S
<input checked="" type="checkbox"/> O/S	PA4	5	12	PA7	<input checked="" type="checkbox"/> O/S
<input checked="" type="checkbox"/> O/S	Any	6	11	PA5	<input checked="" type="checkbox"/> O/S
<input checked="" type="checkbox"/> O/S	Any	7	10	Any	<input checked="" type="checkbox"/> O/S
<input checked="" type="checkbox"/> O/S	Any	8	9	Any	<input checked="" type="checkbox"/> O/S
<input checked="" type="checkbox"/> O/S	Any	0	0	Any	<input checked="" type="checkbox"/> O/S
<input checked="" type="checkbox"/> O/S	Any	0	0	Any	<input checked="" type="checkbox"/> O/S
<input checked="" type="checkbox"/> O/S	Any	0	0	Any	<input checked="" type="checkbox"/> O/S
<input checked="" type="checkbox"/> O/S	Any	0	0	Any	<input checked="" type="checkbox"/> O/S
<input checked="" type="checkbox"/> O/S	Any	0	0	Any	<input checked="" type="checkbox"/> O/S
<input checked="" type="checkbox"/> O/S	Any	0	0	Any	<input checked="" type="checkbox"/> O/S
<input checked="" type="checkbox"/> O/S	Any	0	0	Any	<input checked="" type="checkbox"/> O/S

OK Cancel

- (1) IC Type: Specify the supported IC type.
- (2) Package: Set PIN Count. Only when the IC type is 'User define', users could set PIN Count freely via PIN, the input range is 6~28.
- (3) IC Shift: Set the space needed shift when you place IC in socket; Input range is 0 ~10, default value is 0.
- (4) O/S check: Check the pin whether need O/S test or not, tick the pin that need Open/Short test.
- (5) Settings of writing pin: Set writing pin , non-writing pin choose 『 Any 』 . All writing pin **must** be specified.
- (6) Pin number: Automatic change by the pin count.
(Writing pins are represented by **red**; pins which are not been written are represented by **blue**; others are represented by **gray**.)
- (7) O/S Test Select : Select the pin need to do Open/Short Test.
Enable All PIN: Check all pin.
Only Program PIN: Only check writing pin.
Disable All Pin: No check.

6. Semi-automatic Writing Handler Connection Description

CN1 - Semi-automatic Writing Handler connection port.

Pin	Name	Attribute	Descriptions
1	5V		Power D+5V
2	GND		Ground
3	BUSY	OUTPUT / High Active	Notify Semi-automatic Writing Handler, the Writer is writing IC
4	OK	OUTPUT / High Active	Notify Semi-automatic Writing Handler, the IC has been written successfully
5	NG	OUTPUT / High Active	Notify Semi-automatic Writing Handler, the IC has been written failed
6	START PROGRAM	INPUT / Low Active Active time >200ms	Semi-automatic Writing Handler send information to notify Writer start to write.



External picture

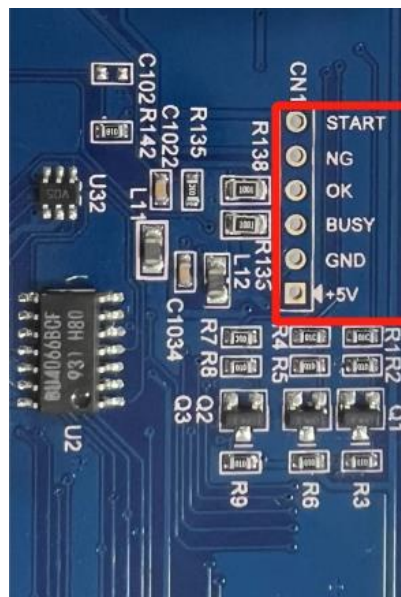

Internal picture

7. Set O/S Test and Blank Check

This chapter explains how to set writer which only do chips' O / S test or blank check. Steps as follows:

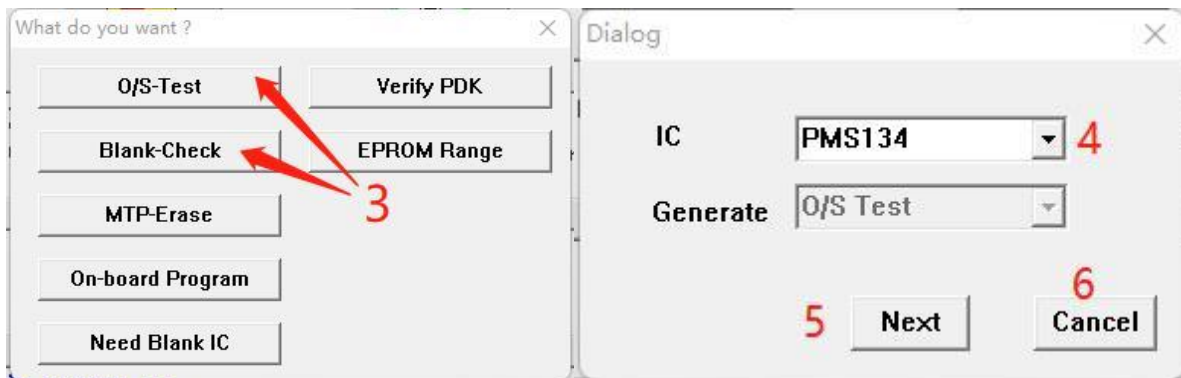
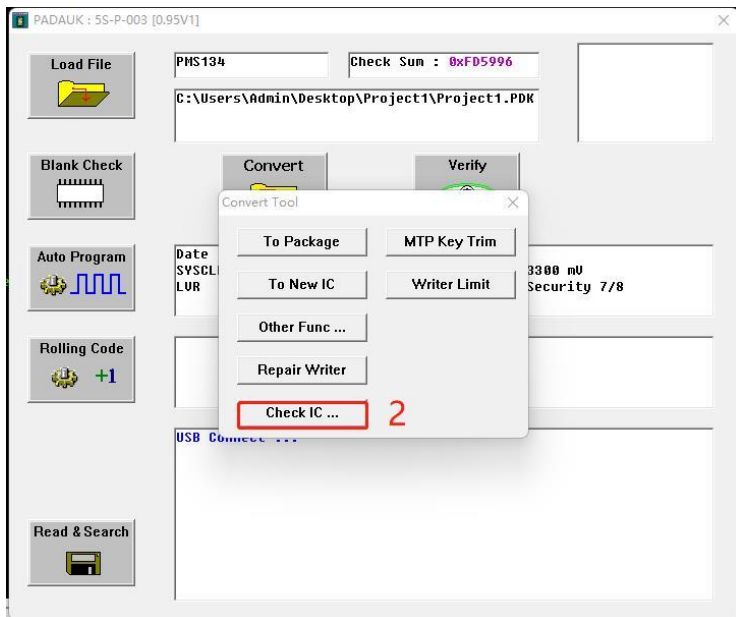
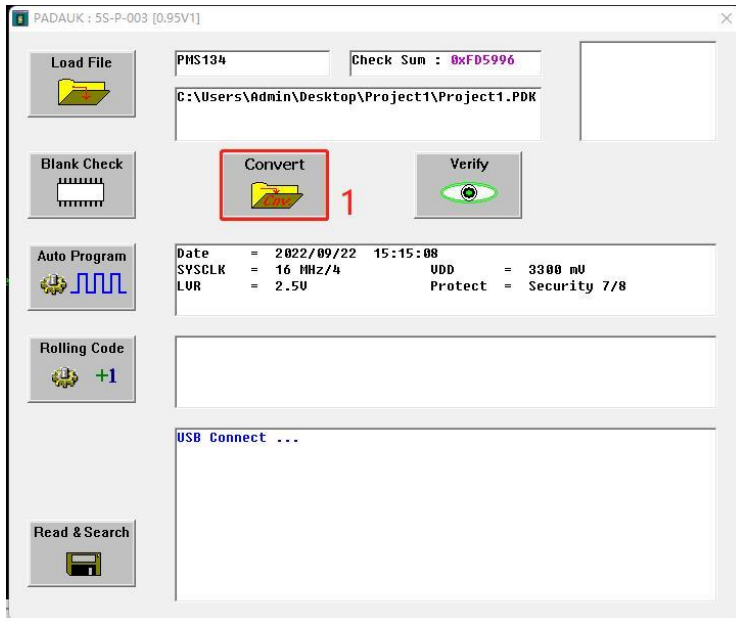

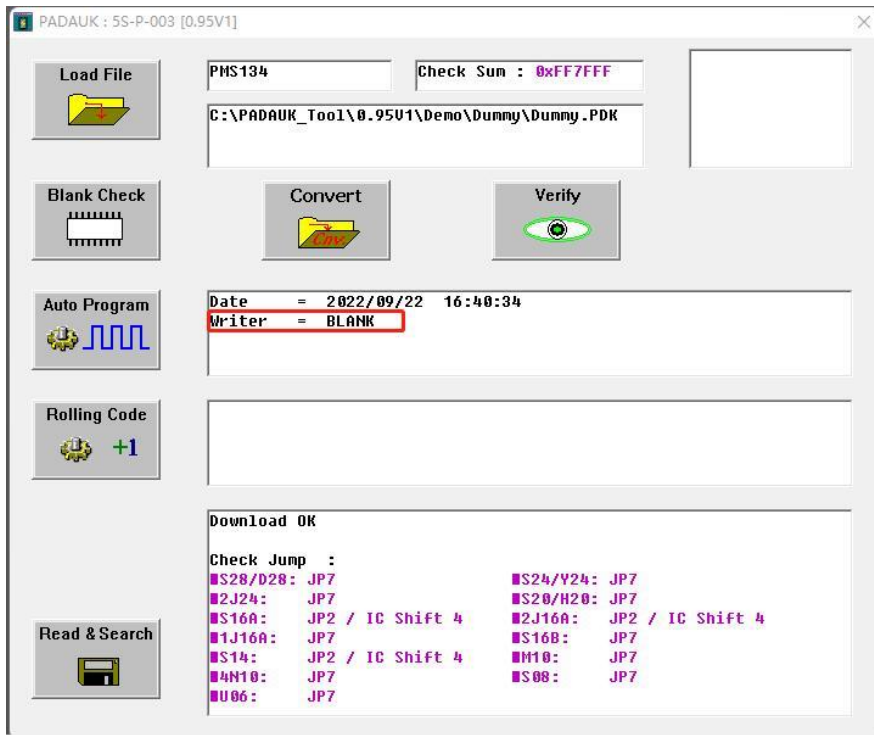

- (1) Click on “ Convert PDK ”
- (2) Click on “ Check IC ”
- (3) Choose “ Set O/S-Test ” or “Set Blank-Check ” to go to the menu.
- (4) Choose IC type (i.e. PMS134).
- (5) Click on “ Next ” to go to next step.
- (6) Or click on “ Cancel ”.
- (7) Enter package setting. Please refer to section 5.6 to get relative descriptions. Click on ” OK ” after complete setting.
- (8) Automatically download the configuration file to the Writer.

After complete the above steps, users can cooperate with semi-automatic equipment just do chips’ O/S tests or blank checks.

NOTICE: Blank Check including O/S test.

8. Writer LCM Information and Buzzer Sound Table

•Writer LCM information:

Item	LCM information	Descriptions	Exclusions and Solutions
1	Wait : Load File	.PDK file was not loaded	Load .PDK file after connect to USB
2	No support...	Writing files is not supported	
3	remove.	IC has been removed	
4	IC ready.	IC is prepared	
5	<<< IC O.K. >>>	Check empty, verify or writing complete	
6	Insert:JP?	Failed to detect JUMPER	Please recheck JUPMER
7	IC O/S test fail O/S: P? Open O/S: P? Short O/S: P? Leak O/S: Fail	IC Open/Short test failed	Please replace IC or remove and put it again or check Jumper, connecting board and settings again.
8	Leak test fail	IO test fail (PMS150G only)	Please replace IC
9	IC Shift:?	Tips IC placement	
10	Do Check... Do Erase.. Do Program... Do Verify... Do Adjust IHRC.. Do Protect...	IC is being checked IC is being erased (MTP only) IC is being written IC is being verified IC is being adjusted IC is being protected	
11	Find a diff. IC.	IC model does not match the writing file	Please replace IC
12	IC not match.	IC's content does not match	Please replace IC
13	Over program cnt	Write failed, more than written	Please replace IC
14	IC Over Current	Writing failed, over current occurred	Please replace IC
15	Over PGM limit	Exceeded writable limit of writer	Reload the .PDK file
16	IC not work(xx)	Writing failed, unable to work	Please replace IC
17	IC Invalid	IC identify failed	Please replace IC
18	IC Ver mismatch	IC/PDK identify failed	Please replace IC or update IDE
19	IC Erase fail.	Erase failed	Please replace IC
20	IC Blank	Blank IC	
21	IC not blank.	Not blank IC	Please replace IC
22	IC verify fail.	IC verify fail	Please replace IC
23	Loss PC Rolling.	Rolling code synchronously failed	USB reconnect, writing software re-execution
24	lose trim data	Invalid IC correction value	Please replace IC
25	Loss IC pkg info	Invalid packing definition	Please check the package definition in the source code

Item	LCM information	Descriptions	Exclusions and Solutions
26	Ver not match.	IC version does not match	Please update the latest writer version
27	Service Call Hold reboot-SW and Repower on	Writing procedure failure	Press SW3 on the back cover, after power on again, connect IDE software update writer
28	E00: SYS-PWR NG	Power self-test failed	Please contact FAE
29	VPP Power fail VDD Power fail	Failed to increase writing voltage	Please replace IC, if this continues to occur, please contact FAE
30	Board/IDE ver. Mismatch (xxx"	Burning self-test failed	Please contact FAE

● **Buzzer sound table :**

Buzzer sound	Introduction	Exclusion and Solutions
1 long beep	Writing failed	Check IC and exclude the possible situation
Continuous short beep (about 6sec)	The IC writing signal has been interrupted abnormally; IC has been removed; IC has been forced out by Semi-automatic Writing Handler	Checking the settings of Semi-automatic Writing Handler writing time
5 consecutive short beeps every 5 seconds	Press and hold the writing button continuously but not release it	Check whether the burning button is stuck

9. Appendix Descriptions

9.1 The difference between 5S-P-003 and 3S-P-002

Project	5S-P-003X	3S-P-002	Notes
O/S test for all pins	support	nonsupport	
Writing time	acceleration		note1
PDK loading time	acceleration		note1
Jumper naming	JPx	CNxx	note2
LCM prompts jumper / IC position	support	nonsupport	
Phase out IC (ex: P232/P234)	nonsupport	support	

Note 1: IC acceleration ratio is related to IC type.

Note 2: Please refer to the relevant table to learn about the connection between Jumper(JPx)and IC type/package.

9.2 The difference between 5S-P-003 and 5S-P-003BX

- (1) Enhance the power input range
- (2) Improvement of antistatic interference capability
- (3) When writing some chips, the PA5 and VDD of the writer Jump need to be exchanged (**swap**).

9.2 Special notes of MTP On-board writing

MTP series enable to support On-board writing.

Take PFS154 as an example (please refer to PFS154 data sheet to learn about other MTP chip writing wire) There are five wires of on-board writing, one clock wire ICPCCK and one data wire ICPDA, and three other power wires are VDD, GND and writing voltage VPP. In the follow wiring table of on-board writing, the ☆ of wiring table may be resistor or capacitor, and the conditions of wiring circuit as follows:

PIN	Resistance	Capacitance
V _{DD} / GND	---	Capacitance must be less than or equal to 0.1 UF
PA3 / PA5 / PA6	Resistance must bigger than or equal to 10KΩ	Capacitance must be less than or equal to 220pF

At the same time, set O/S test to writing pin particularly according to section 5.5.

Notice:

- (1) The voltage is as high as 8V (PA5/VPP) when writing. Please confirm the peripheral parts could withstand the voltage.
- (2) VDD cannot be limited to 5.0V or below to 5.0 V. If must connect 5.1V Zener diodes to VDD, please select 『On-board Program』 on the writer interface

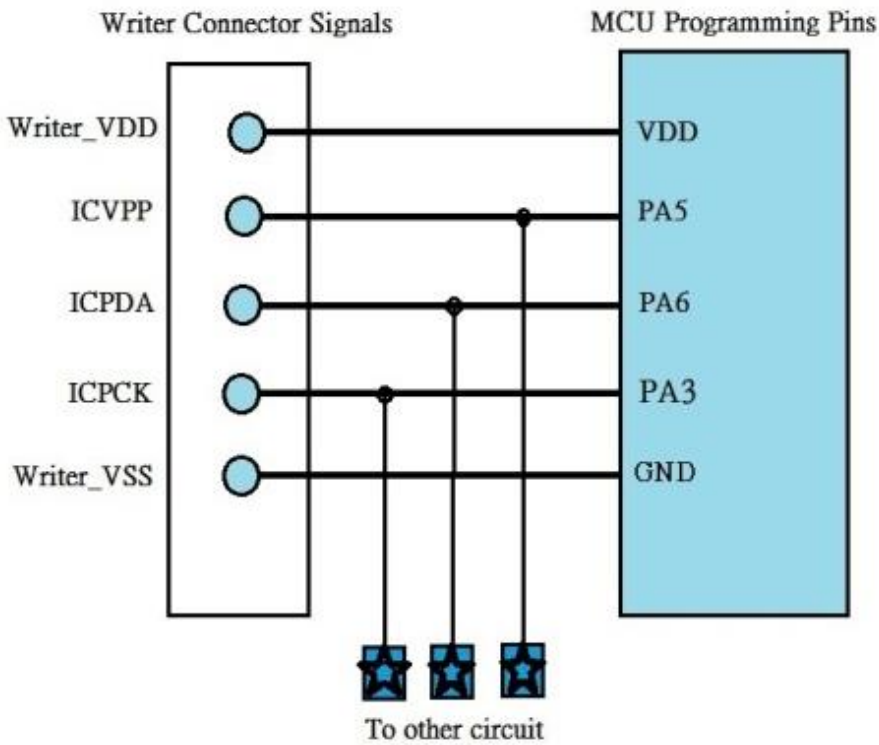

The ticking steps of MTP On-board VDD limitation:

- (1) Click on 『 Convert PDK 』
- (2) Click on 『 To Package 』
- (3) Click on 『 MTP On-board VDD limitation 』

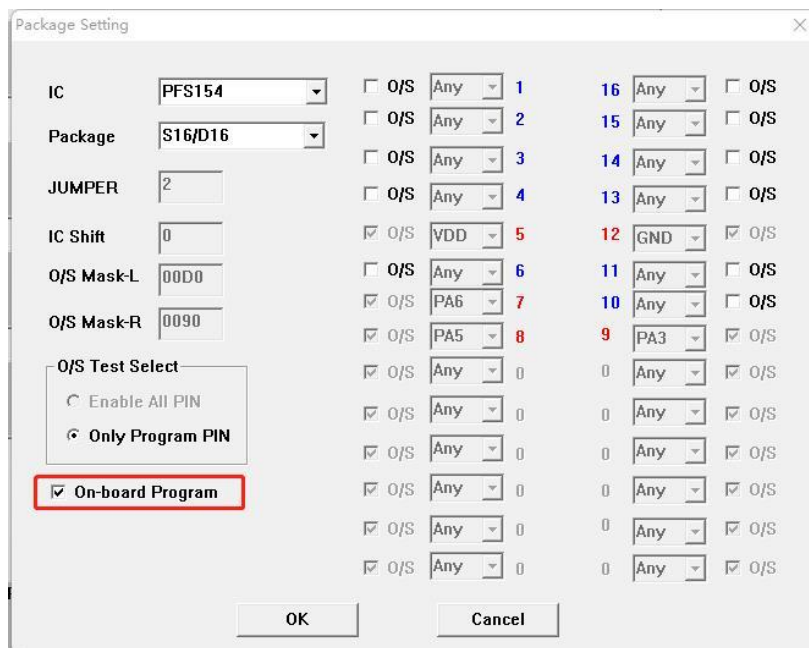

9.3 Special notes of voltage while On-board or Multi-Chip-IC writing (OTP / MTP)

- (1) When programming, VPP may be higher than 11V, and VDD maximum supply current is not over 20mA.
- (2) VDD may be higher than 7.5V for PDKxx/P2xx series ICs; for other series ICs, VDD may be higher than 6.5V (Each chip will be different, please refer to the specification of the chip used).
- (3) The voltage of other program pins (except GND) is the same as VDD.

If you have On-board writing or Multi-Chip (ex: MOS, EEPROM, and 2.4G), be sure to pay attention to above notification. Please follow the instruction in Section 9.2, especial for MTP voltage limitation.